

1993 Vulcan 500 PARTS DIAGRAM

Battery Case

F2132

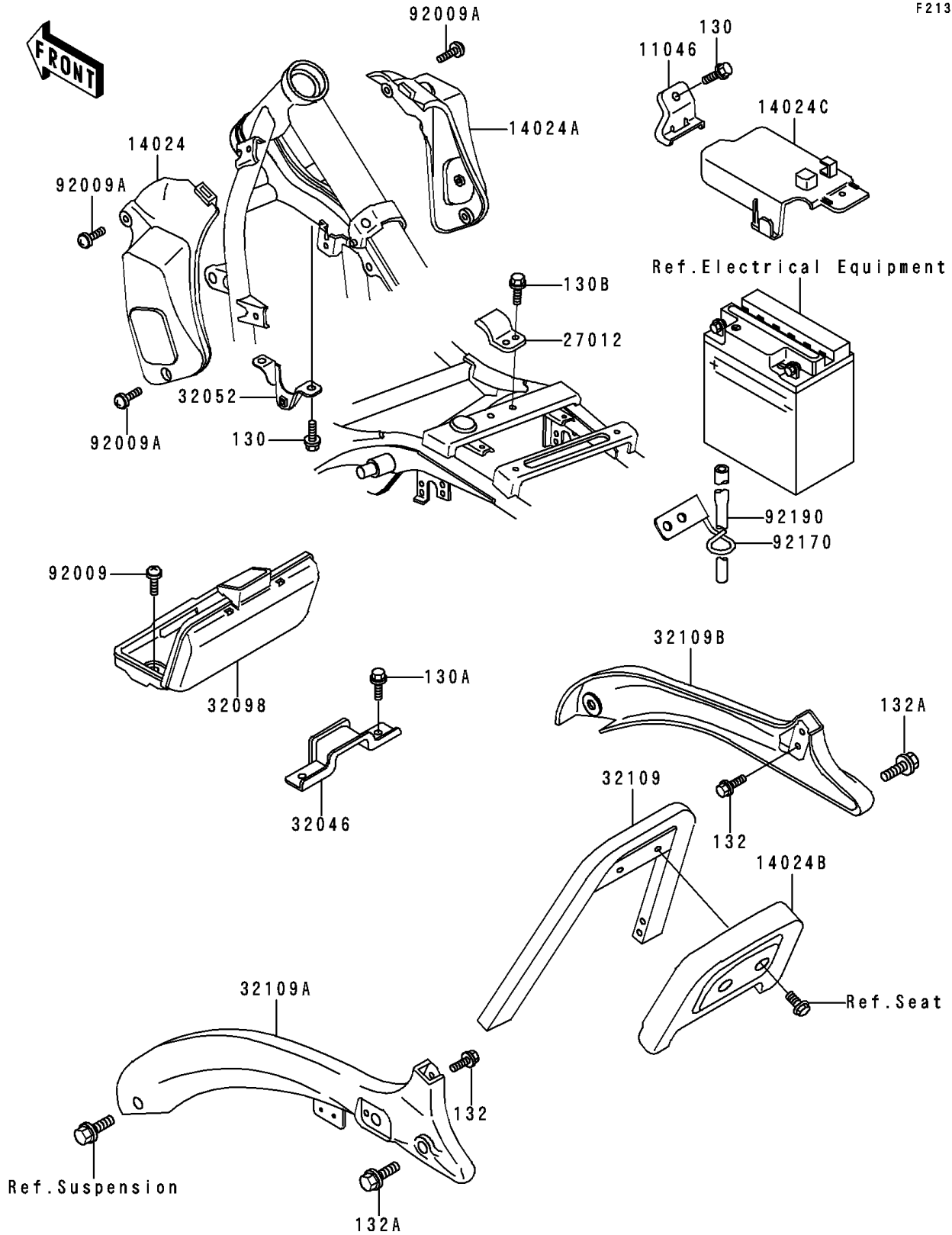

1993 Vulcan 500 PARTS LIST

Battery Case

ITEM NAME	PART NUMBER	QUANTITY
-----------	-------------	----------