

1980 LTD PARTS DIAGRAM

CRANKCASE ('80 A1)

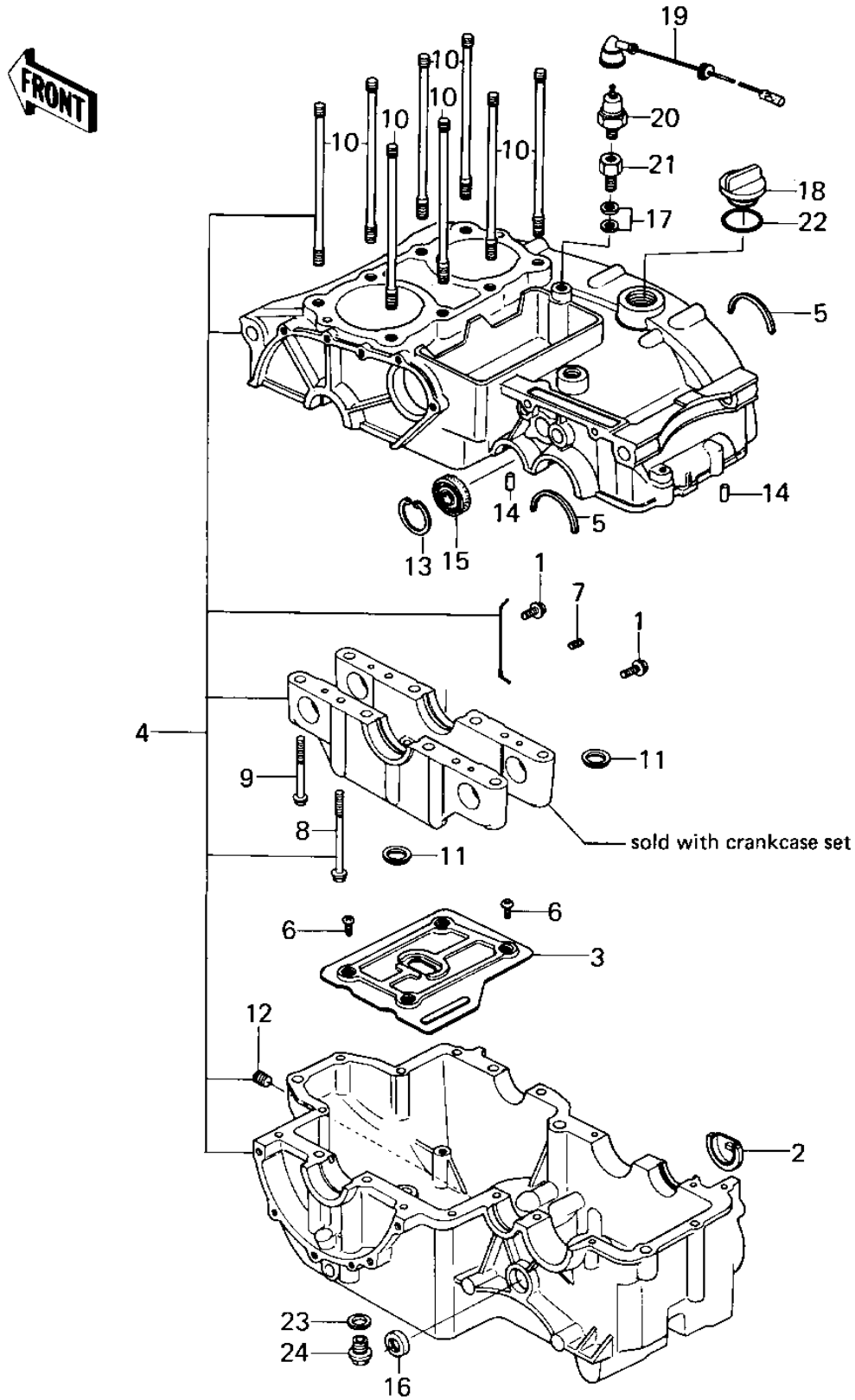

1980 LTD PARTS LIST

CRANKCASE ('80 A1)

ITEM NAME	PART NUMBER	QUANTITY
BOLT,FLANGED,6X8 (Ref # 1)	130P0608	2
RECEIVER,OIL (Ref # 2)	13045-1001	1
PLATE,CRANKCASE (Ref # 3)	13169-1103	1
SET-CRANKCASE (Ref # 4)	14001-5087	1
RING BEARING SETTING (Ref # 5)	14013-004	2
SCREW PAN HEAD 6X12 (Ref # 6)	220B0612	4
SCREW,6X6 (Ref # 7)	290Q0606	1
BOLT,FLANGED,10X91 (Ref # 8)	92001-1004	4
BOLT,FLANGED,8X58 (Ref # 9)	92001-1005	4
BOLT,FLANGED,8X58 (Ref # 9)	92001-1005	4
BOLT,FLANGED,8X58 (Ref # 9)	92001-1005	2
STUD,10X153 (Ref # 10)	92004-062	2
STUD,10X153 (Ref # 10)	92004-062	2
O RING,0.D=18MM (Ref # 11)	92055-048	2
PLUG,OIL SWITCH (Ref # 12)	92066-059	2
PLUG,OIL SWITCH (Ref # 12)	92066-059	2
CIRCLIP,36M/M (Ref # 13)	481J3600	1
PIN DOWEL 6MM (Ref # 14)	92042-016	2
OIL SEAL,PUSH ROD (Ref # 15)	92049-1041	1
OIL SEAL,TB13225.5 (Ref # 16)	92051-005	1
GASKET,10X14.5X1.5 (Ref # 17)	11009-1105	2
PLUG,OIL FILLER (Ref # 18)	16115-013	1
WIRE,LEAD,OIL SWITCH (Ref # 19)	26011-1078	1
SWITCH,OIL PRESSURE (Ref # 20)	27010-1157	1
BOLT,OIL SWITCH (Ref # 21)	92001-1020	1
"O" RING,31MM (Ref # 22)	92055-049	1
GASKET,DRIN PLUG (Ref # 23)	92065-097	1
PLUG,OIL DRAIN,12X15 (Ref # 24)	92066-1174	1