

1983 LTD Shaft PARTS DIAGRAM

CHASSIS ELECTRICAL EQUIPMENT

F2760-0217

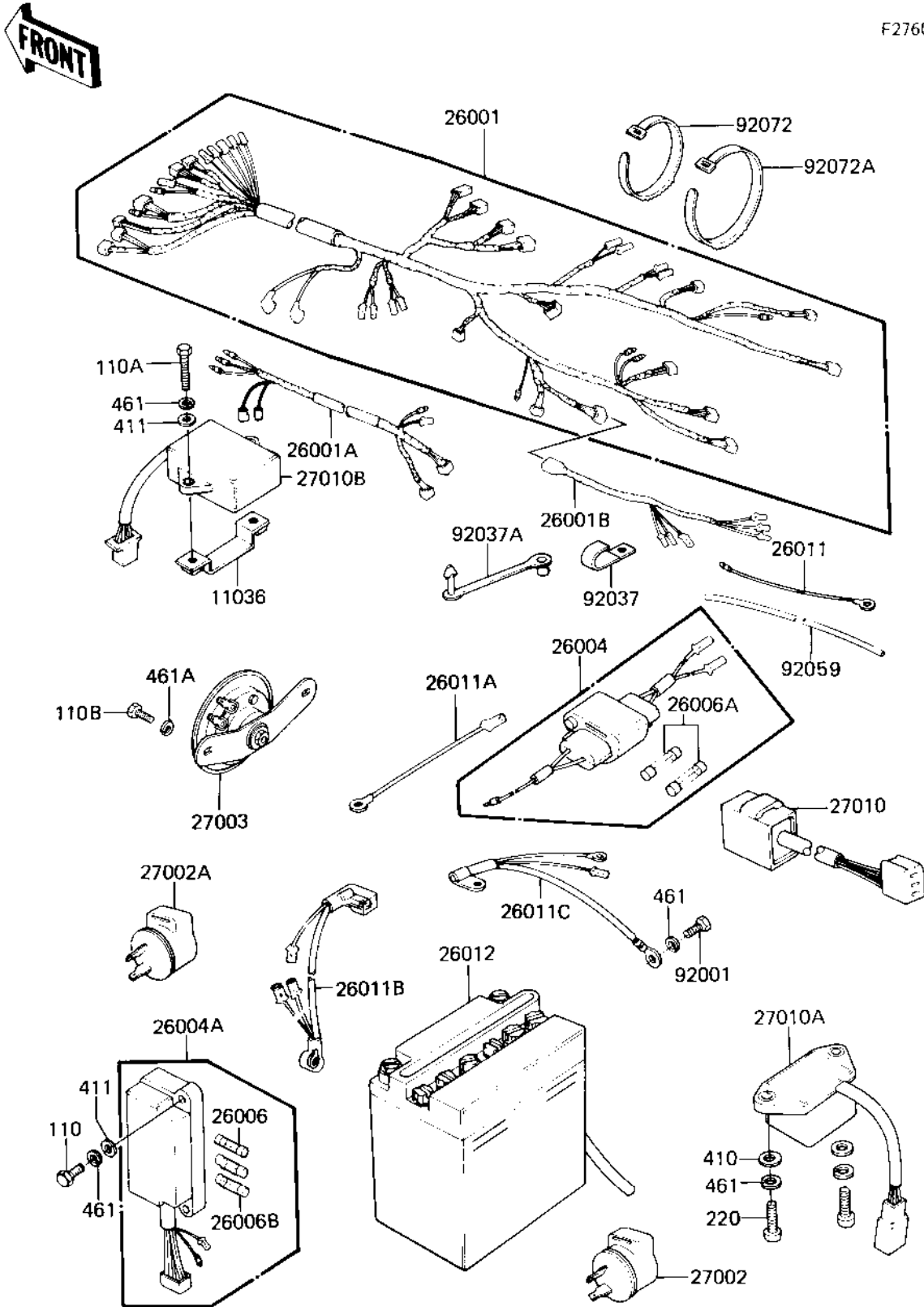

1983 LTD Shaft PARTS LIST

CHASSIS ELECTRICAL EQUIPMENT

ITEM NAME	PART NUMBER	QUANTITY
BRACKET-A,SIGNAL SWIT (Ref # 11036)	11036-1549	1
HARNESS,MAIN (Ref # 26001)	26001-1412	1
HARNESS,CNT (Ref # 26001A)	26001-1427	1
WIRING HARNESS,REAR (Ref # 26001B)	26002-063	1
FUSE-ASSY,ACCESSORY (Ref # 26004)	26004-1016	1
FUSE-ASSY (Ref # 26004A)	26004-1019	1
FUSE 10A (Ref # 26006)	26006-003	5
FUSE,10A,L=30M/M (Ref # 26006A)	26006-1002	3
FUSE,30A,L=25M/M (Ref # 26006B)	26006-1005	2
WIRE,LEAD (Ref # 26011)	26011-095	2
WIRE-LEAD,ACCESSORY G (Ref # 26011A)	26011-1100	1
WIRE-LEAD,BATTERY (Ref # 26011B)	26011-1163	1
WIRE-LEAD,BATTERY GRO (Ref # 26011C)	26011-1164	1
YUA BAT YB14L-A2 (Ref # 26012)	26012-1008	1
RELAY-TURN SIGNAL (Ref # 27002)	27002-011	1
RELAY,TURN SIGNAL (Ref # 27002A)	27002-016	1
HORN (Ref # 27003)	27003-1073	1
SWITCH,PILOT LAMP CHE (Ref # 27010)	27010-1059	1
SWITCH,RESERV LIGHTIN (Ref # 27010A)	27010-1066	1
SWITCH,TURN SIGNAL OP (Ref # 27010B)	27010-1077	1
BOLT,HEX HEAD,6MM (Ref # 92001)	92001-137	1
CLAMP,WIRING HARNESS (Ref # 92037)	92037-1069	1
CLAMP (Ref # 92037A)	92037-1290	1
TUBE,P.V.C,8X9X200 (Ref # 92059)	92059-1150	2
BAND,MIDDLE (Ref # 92072)	92072-031	2
BAND,WIRING HARNESS (Ref # 92072A)	92072-056	3
BOLT 6X22 (Ref # 110)	112B0622	2
UNAVAILABLE IN PRICE BOOK (Ref # 110A)	110M0630	2
BOLT, 6X12, BLACK (Ref # 110B)	112C0612	2

1983 LTD Shaft PARTS LIST

CHASSIS ELECTRICAL EQUIPMENT

ITEM NAME	PART NUMBER	QUANTITY
SCREW PAN HEAD 6X20 (Ref # 220)	220B0620	2
WASHER PLAIN 6MM (Ref # 410)	410B0600	2
WASHER PLAIN 6MM (Ref # 411)	411B0600	4
WASHER SPRING 6MM (Ref # 461)	461F0600	7
WASHER-SPRING,6MM,BLA (Ref # 461A)	461K0600	2