

1985 Voyager PARTS DIAGRAM

STARTER MOTOR/STARTER CLUTCH

E1840-0057

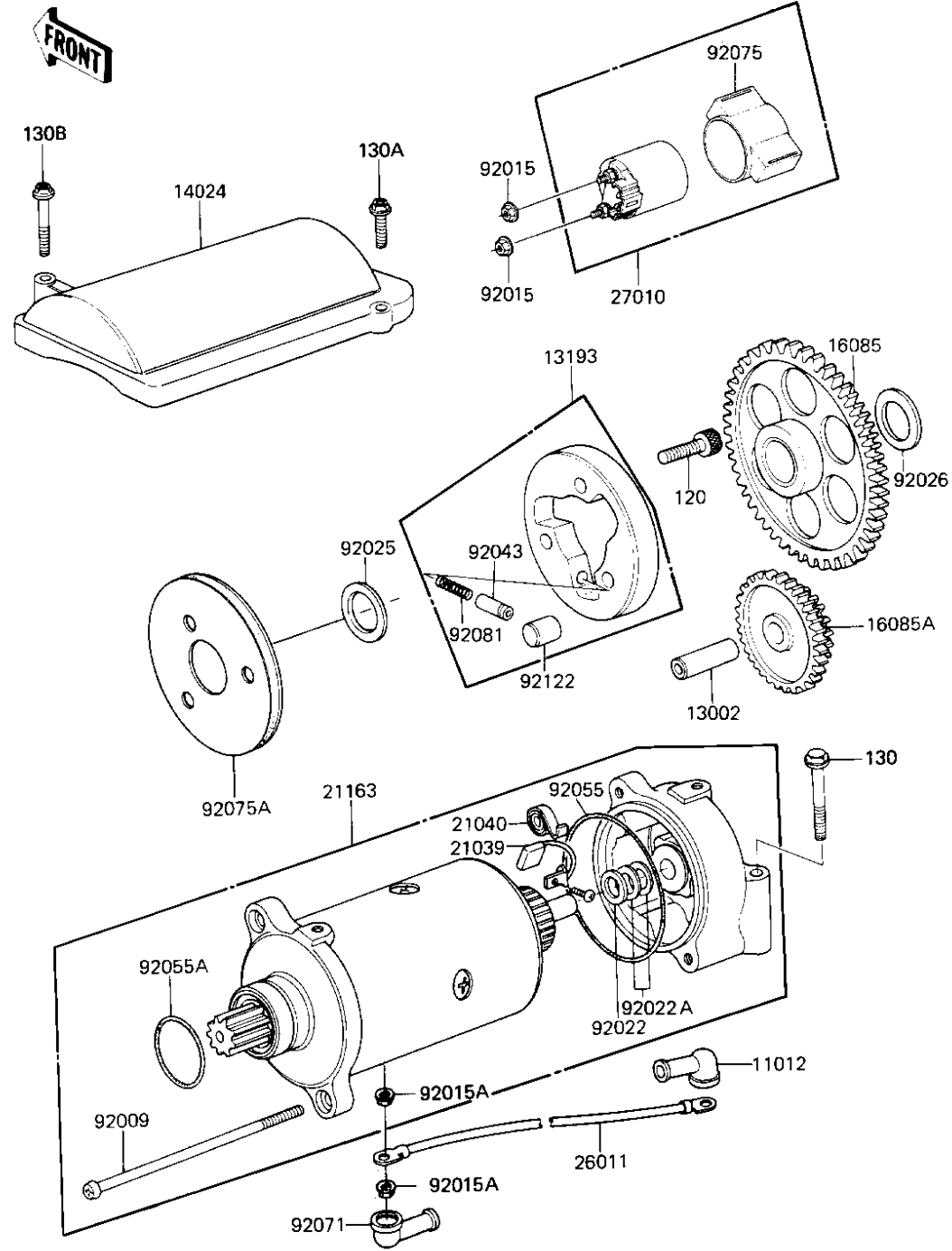

Ref	No
11	
13	
13	
14	
16	
16	
21	
21	
21	
21	
26	
27	
92	
92	
92	
92	
92	
92	
92	
92	
92	
92	
92	
92	
92	
92	
92	

1985 Voyager PARTS LIST

STARTER MOTOR/STARTER CLUTCH

ITEM NAME	PART NUMBER	QUANTITY
CAP,TERMINAL (Ref # 11012)	11012-1354	1
PIN-PISTON (Ref # 13002)	13002-019	1
CLUTCH-ASSY-ONEWAY (Ref # 13193)	13193-1012	1
COVER,STARTER MOTOR (Ref # 14024)	14025-1752	1
GEAR,STARTER CLUTCH,6 (Ref # 16085)	16085-1040	1
GEAR,STARTER REDUCTIO (Ref # 16085A)	16085-1041	1
CARBON BRUSH (Ref # 21039)	21039-003	2
SPRING,CARBON BRUSH (Ref # 21040)	21040-003	2
STARTER-ELECTRIC (Ref # 21163)	21163-1059	1
WIRE-LEAD,STARTER MOT (Ref # 26011)	26011-1263	1
SWITCH,MAGNETIC (Ref # 27010)	27010-1235	1
SCREW,PAN HEAD,6X110 (Ref # 92009)	21015-005	2
NUT-6MM (Ref # 92015)	92015-1078	2
NUT-6MM (Ref # 92015A)	92015-1078	2
WASHER,THRUST,1.6T (Ref # 92022)	21025-010	1
WASHER,THRUST,0.2T (Ref # 92022A)	21025-011	AR
SHIM,25.3X36X0.3 (Ref # 92025)	92025-1019	1
SPACER,25X34X2.3 (Ref # 92026)	92026-1059	1
PIN (Ref # 92043)	92043-087	3
"0" RING,STARTING MTR (Ref # 92055)	21027-003	2
"0" RING,STARTING MTR (Ref # 92055A)	21027-004	1
GROMMET,CORD (Ref # 92071)	21017-017	1
DAMPER MAG SWITCH SHK (Ref # 92075)	21064-002	1
DAMPER (Ref # 92075A)	92075-1390	1
SPRING (Ref # 92081)	92081-110	3
ROLLER (Ref # 92122)	92122-004	3
BOLT,SOCKET,8X25 (Ref # 120)	120P0825	3
BOLT,FLANGED,6X55 (Ref # 130)	130G0655	2
BOLT-FLANGED (Ref # 130A)	130N0625	1