

1975 G5-C PARTS DIAGRAM

CYLINDER HEAD/CYLINDER ('74-'75 B/C)

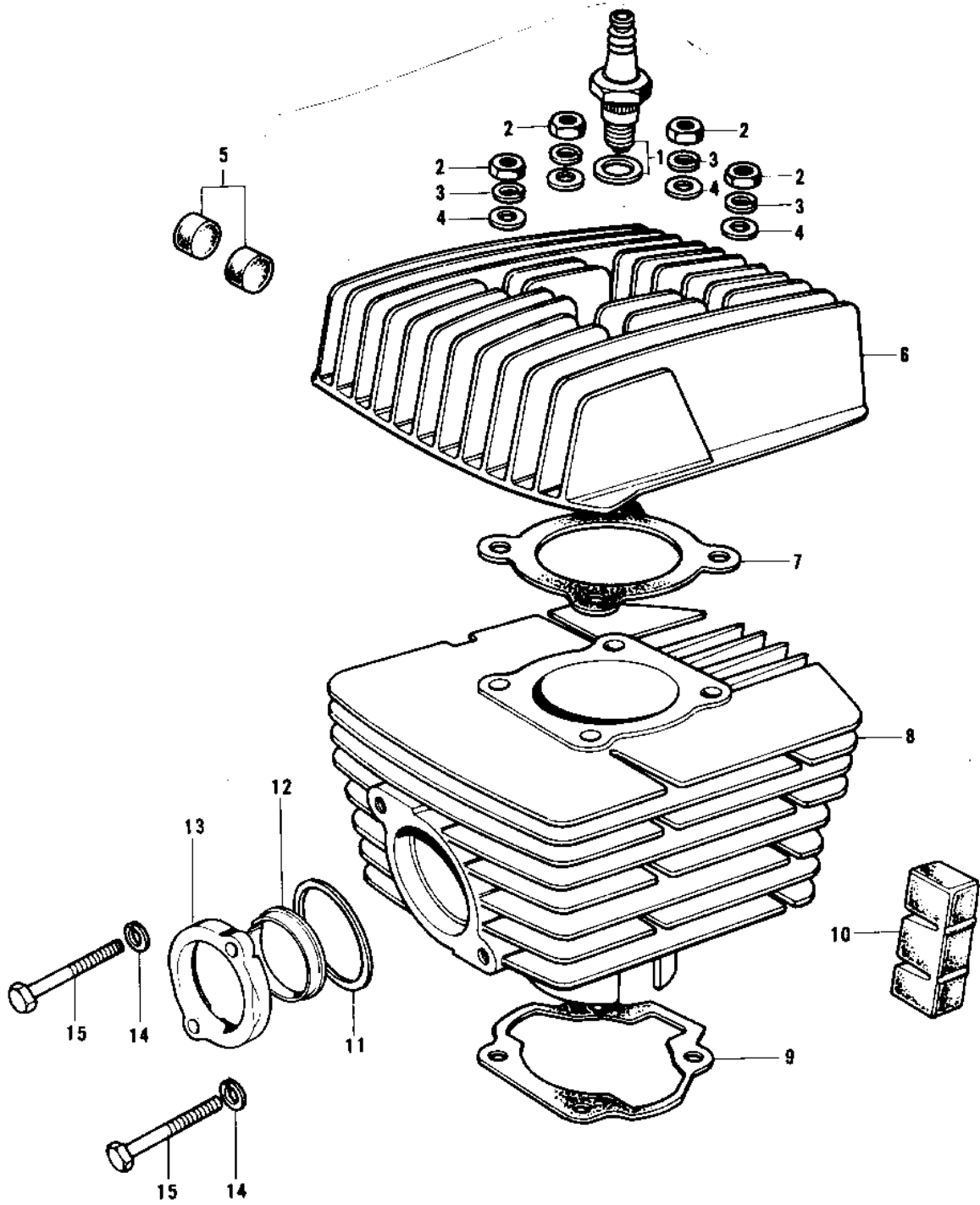

1975 G5-C PARTS LIST

CYLINDER HEAD/CYLINDER ('74-'75 B/C)

ITEM NAME	PART NUMBER	QUANTITY
SPARK PLUGS B8HC (Ref # 1)	92070-010	
NUT,8MM (Ref # 2)	311B0800	
WASHER SPRING 8MM (Ref # 3)	461F0800	
WASHER PLAIN 8MM (Ref # 4)	410B0800	
DAMPER RUBBER (Ref # 5)	92075-074	
CYLINDER HEAD,BLACK (Ref # 6)	11001-075-21	
GASKET CYLINDER HEAD (Ref # 7)	11004-033	
CYLINDER,BLACK (Ref # 8)	11005-1027	
GASKET,CYLINDER BASE (Ref # 9)	11060-1200	
DAMPER RUBBER,CYLIND (Ref # 10)	92075-170	
GASKET,EXHAUST PIPE (Ref # 11)	11009-1992	
INSERT,EXH PIPE HLDR (Ref # 12)	18070-008	
HOLDER,EXHAUST PIPE (Ref # 13)	18069-048	
WASHER SPRING 6MM (Ref # 14)	461F0600	
BOLT-UPSET (Ref # 15)	112G0625	