

# 1976 KH100-B7 PARTS DIAGRAM

CYLINDER HEAD/CYLINDER

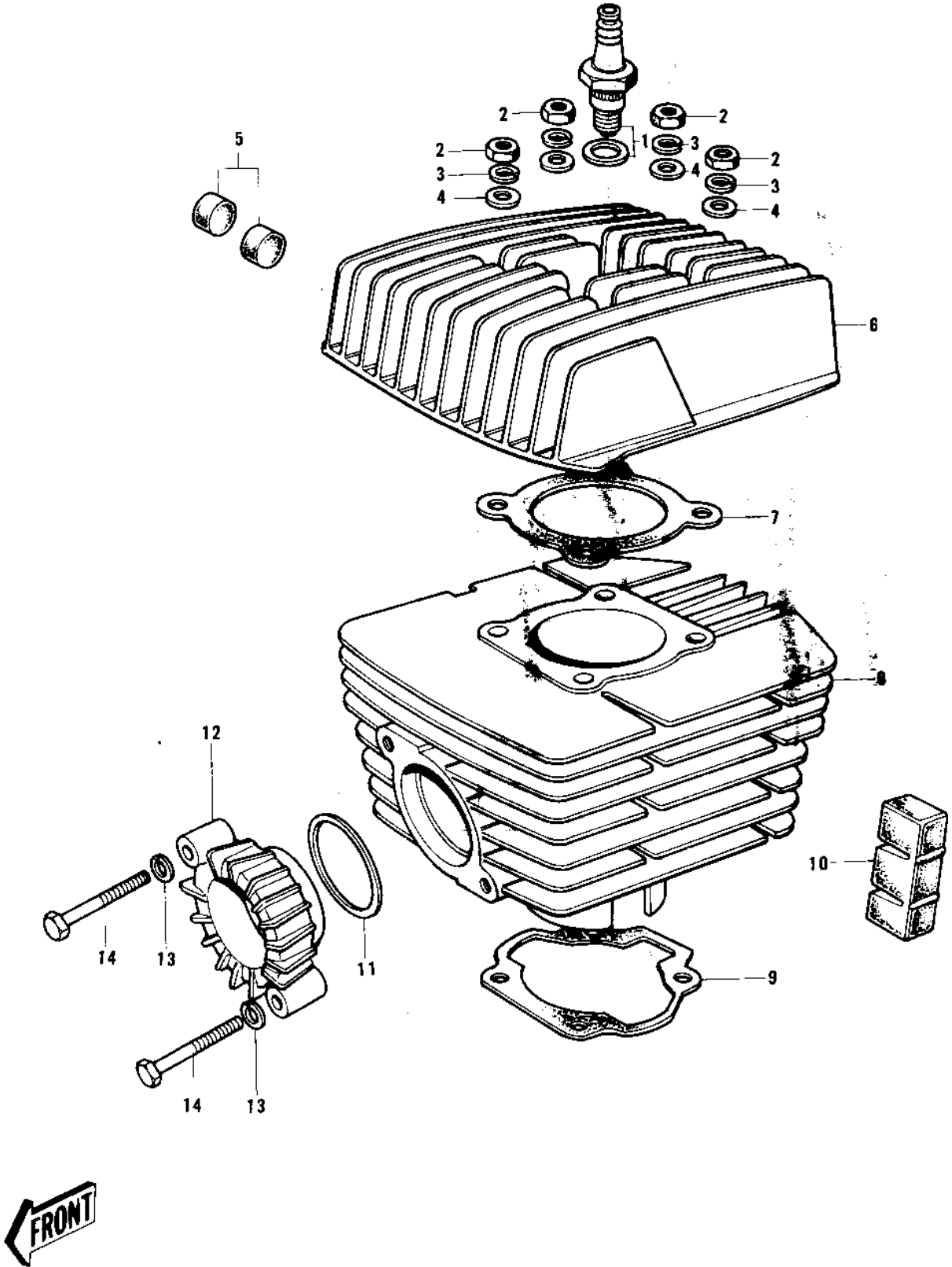

## 1976 KH100-B7 PARTS LIST

### CYLINDER HEAD/CYLINDER

ITEM NAME	PART NUMBER	QUANTITY
SPARK PLUGS B8HC (Ref # 1)	92070-010	1
SPARK PLUG B8HS (Ref # 1)	B8HS	1
NUT,8MM (Ref # 2)	311B0800	4
WASHER SPRING 8MM (Ref # 3)	461F0800	4
WASHER PLAIN 8MM (Ref # 4)	410B0800	4
DAMPER RUBBER (Ref # 5)	92075-074	8
CYLINDER HEAD (Ref # 6)	11001-075	1
GASKET CYLINDER HEAD (Ref # 7)	11004-033	1
CYLINDER,BLACK (Ref # 8)	11005-1027	1
GASKET,CYLINDER BASE (Ref # 9)	11060-1200	1
DAMPER RUBBER,CYLIND (Ref # 10)	92075-170	2
GASKET,EXHAUST PIPE (Ref # 11)	11009-1992	1
CLAMP EXHAUST PIPE (Ref # 12)	18069-004	1
WASHER SPRING 6MM (Ref # 13)	461F0600	2
BOLT,HEX HEAD,6X50 (Ref # 14)	110G0650	2