

# 1980 KM100 PARTS DIAGRAM

CLUTCH

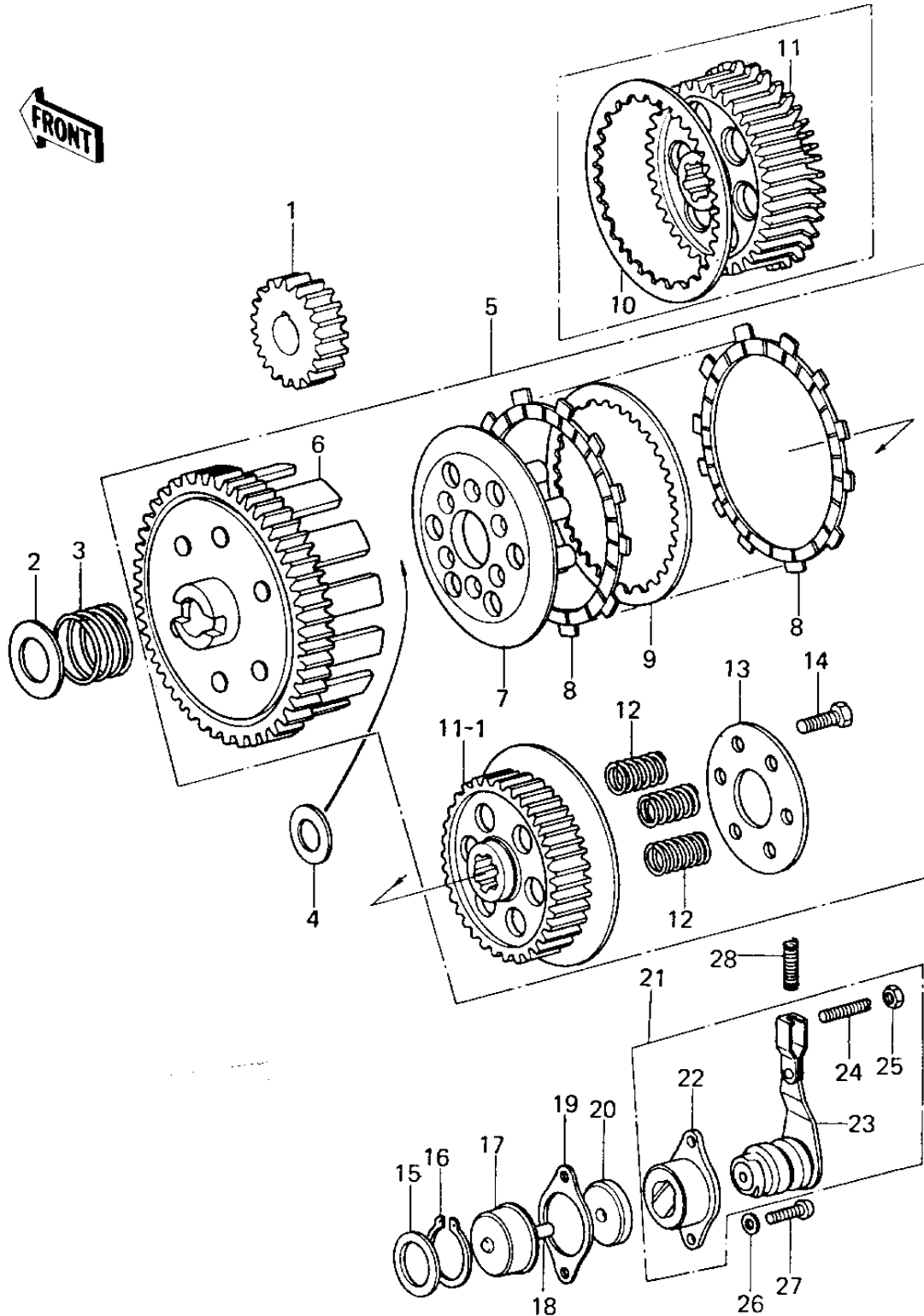

# 1980 KM100 PARTS LIST

## CLUTCH

ITEM NAME	PART NUMBER	QUANTITY
PINION,PRIMARY (Ref # 1)	13121-032	1
WASHER PLAIN (Ref # 2)	92022-057	1
SPRING CLUTCH DAMPER (Ref # 3)	92081-015	1
WASHER THRUST CLUTCH (Ref # 4)	92022-054	1
CLUTCH-ASSY (Ref # 5)	13081-028	1
HOUSING CLUTCH (Ref # 6)	13095-022	1
WHEEL,CLUTCH (Ref # 7)	13086-1002	1
WHEEL,CLUTCH (Ref # 7)	13086-1002	1
PLATE-FRICTION (Ref # 8)	13088-1103	4
PLATE-CLUTCH,STEEL (Ref # 9)	13089-1009	3
PLATE CLUTCH OUTER (Ref # 10)	13090-004	1
HUB,CLUTCH (Ref # 11)	13087-1011	1
HUB,CLUTCH (Ref # 11-1)	13087-1011	1
SPRING CLUTCH (Ref # 12)	92081-012	6
HOLDER,CLUTCH SPRING (Ref # 13)	13091-1115	1
BOLT-UPSET (Ref # 14)	112G0516	6
WASHER THRUST (Ref # 15)	92022-053	1
CIRCLIP 16MM (Ref # 16)	480J1600	1
UNAVAILABLE IN PRICE BOOK (Ref # 13113-)		1
PIN,DOWEL (Ref # 18)	92042-043	1
GASKET,CLUTCH RELEASE (Ref # 19)	11060-1197	1
OIL SEAL (Ref # 20)	92050-071	1
RELEASE-ASSY-CLUTCH (Ref # 21)	13231-1008	1
RELEASE-ASSY-CLUTCH (Ref # 22)	13231-1008	1
RELEASE-ASSY-CLUTCH (Ref # 23)	13231-1008	1
SCREW,SLOTTED,6X16 (Ref # 24)	291H0616	1
NUT 6MM (Ref # 25)	312B0600	1
WASHER PLAIN 6MM (Ref # 26)	410B0600	2
SCREW PAN HEAD 6X16 (Ref # 27)	220B0616	2