

1975 F7-D PARTS DIAGRAM

CYLINDER HEAD/CYLINDER ('71-'73 F7/F7-A/

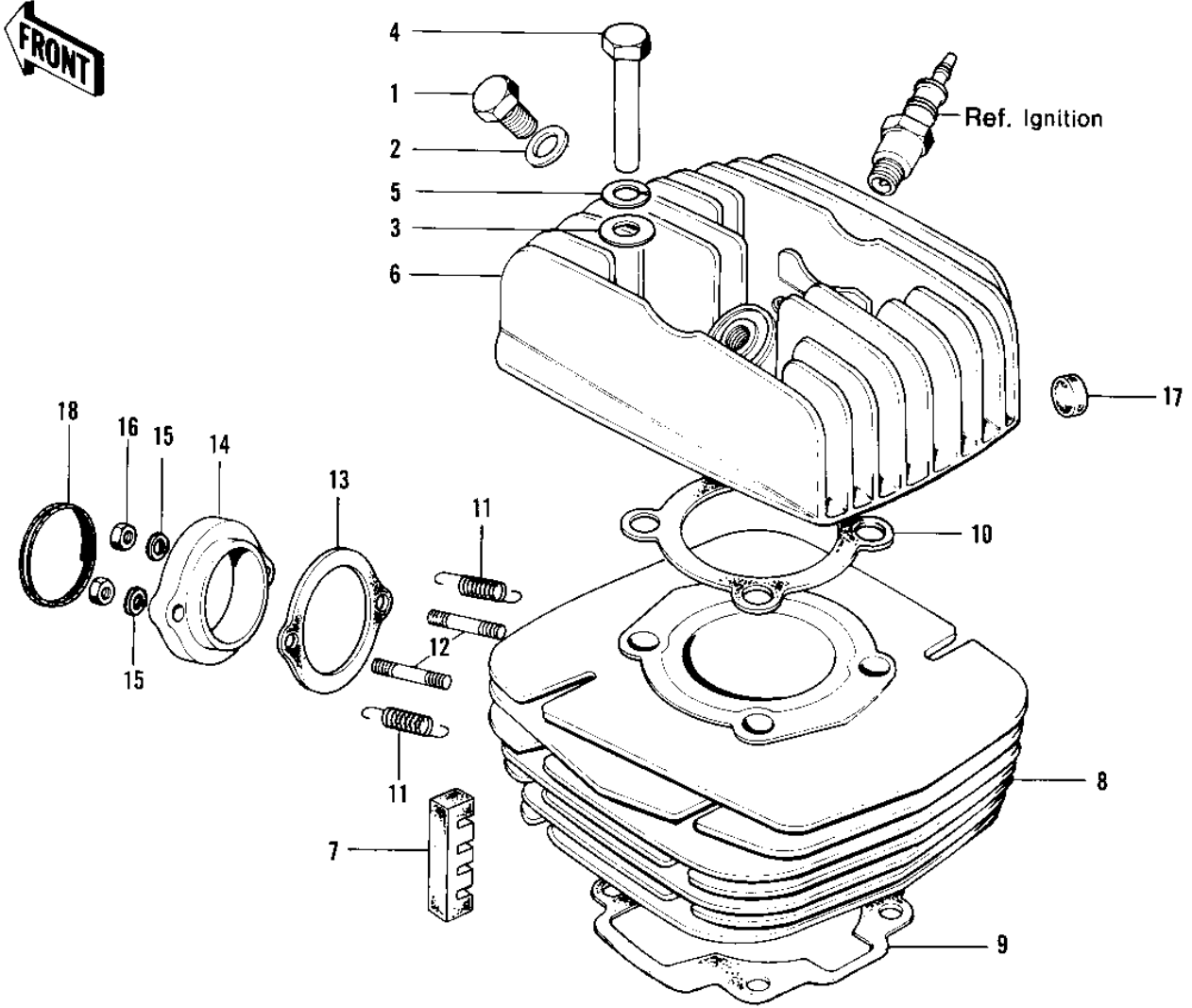

F7-B: Location of Damper Rubber

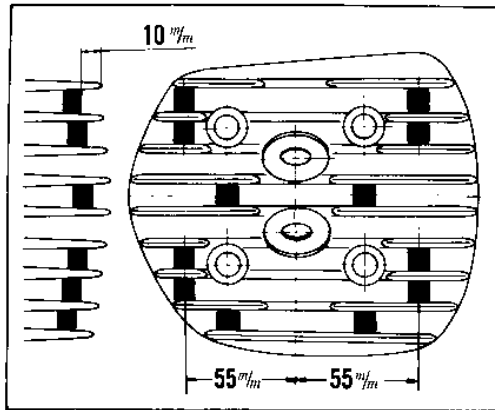

1975 F7-D PARTS LIST

CYLINDER HEAD/CYLINDER ('71-'73 F7/F7-A/

ITEM NAME	PART NUMBER	QUANTITY
PLUG-CYLINDER HEAD (Ref # 1)	92067-005	
GASKET-CYL HEAD PLUG (Ref # 2)	92065-068	
WASHER PLAIN 12MM (Ref # 3)	92022-072	
NUT 8MM (Ref # 4)	92015-020	
WASHER SPRING 12MM (Ref # 5)	461F1200	
CYLINDER HEAD (Ref # 6)	11001-052	
CYLINDER HEAD,BLACK (Ref # 6)	11001-092-21	
CYLINDER HEAD,BLACK (Ref # 6)	11001-092-21	
DAMPER RUBBER-CYLINDER (Ref # 7)	92075-142	
CYLINDER (Ref # 8)	11005-5002	
CYLINDER (Ref # 8)	11005-5002	
CYLINDER (Ref # 8)	11005-5002	
GASKET-CYLINDER BASE (Ref # 9)	11009-026	
GASKET-CYLINDER HEAD (Ref # 10)	11004-042	
SPRING CONNECTOR (Ref # 11)	18071-001	
SPRING-CONNECTOR (Ref # 11)	18071-003	
STUD, LIGHT ALLOY, 6X30 (Ref # 12)	172G0630	
GASKET-EXHAUST PIPE (Ref # 13)	18067-017	
HOLDER-EXHAUST (Ref # 14)	18062-005	
HOLDER-EXH PIPE,BLACK (Ref # 14)	18062-005-21	
WASHER SPRING 6MM (Ref # 15)	461F0600	
NUT 6MM (Ref # 16)	311B0600	
NUT (Ref # 16)	92019-008	
DAMPER RUBBER (Ref # 17)	92075-075	
UNAVAILABLE IN PRICE BOOK (Ref # 18)	56019-102	