

1983 Duckster PARTS DIAGRAM

BATTERY CASE/TOOL CASE ('83 KLT200-A4/A4)

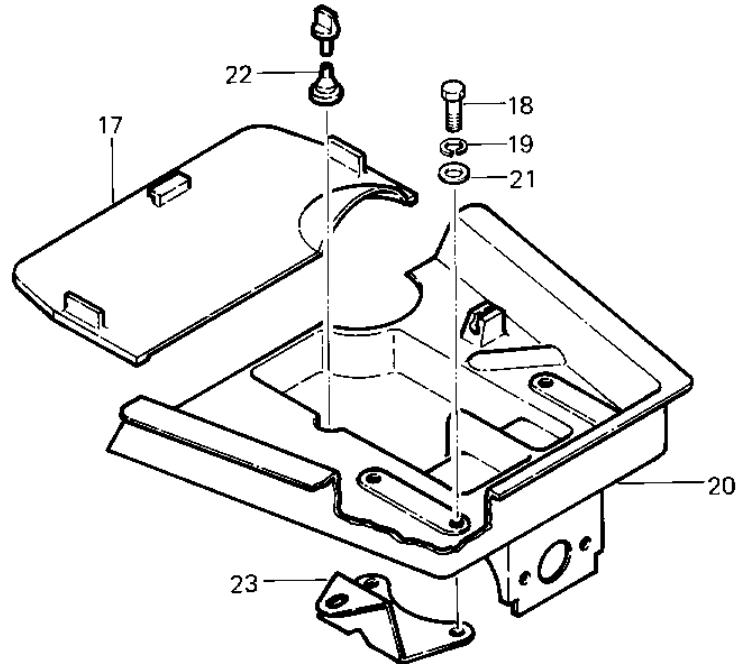
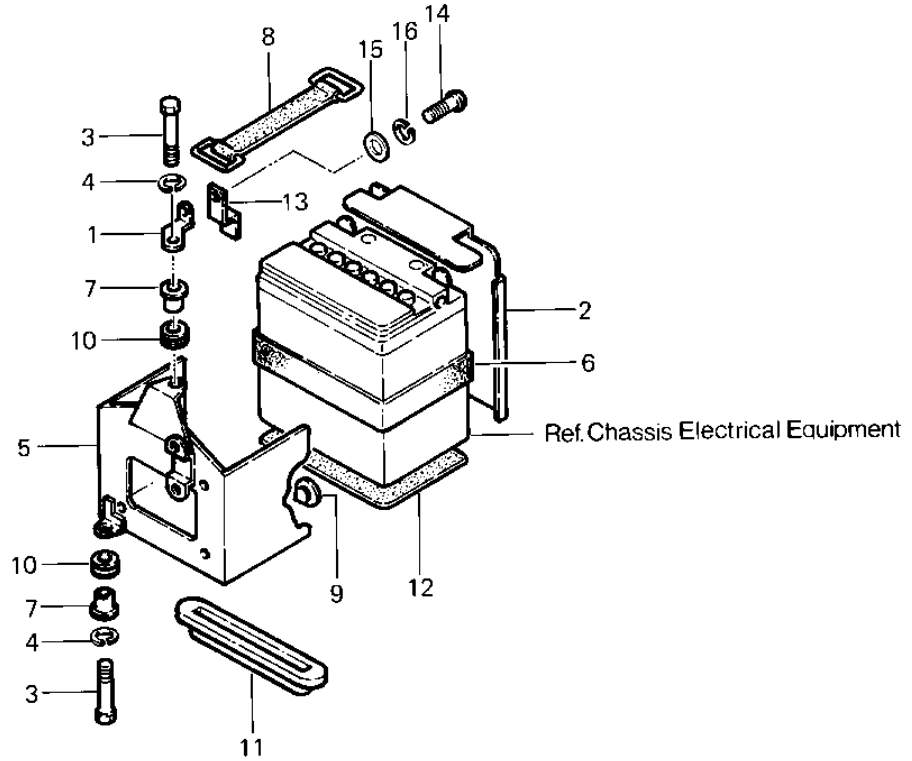

1983 Duckster PARTS LIST

BATTERY CASE/TOOL CASE ('83 KLT200-A4/A4)

ITEM NAME	PART NUMBER	QUANTITY
BRACKET (Ref # 1)	11034-4051	1
COVER (Ref # 2)	14025-4007	1
BOLT-UPSET,6X20 (Ref # 3)	112G0620	2
WASHER SPRING 6MM (Ref # 4)	461F0600	2
CASE-BATTERY (Ref # 5)	32097-4004	1
MAT-BATTERY SIDE (Ref # 6)	32103-023	1
COLLAR (Ref # 7)	92027-1045	2
BAND BATTERY (Ref # 8)	92072-006	1
DAMPER RUBBER (Ref # 9)	92075-078	4
DAMPER RUBBER (Ref # 10)	92075-277	2
DAMPER RUBBER (Ref # 11)	92075-280	1
DAMPER,BATTERY CASE (Ref # 12)	92075-4019	1
HOLDER-BATTERY (Ref # 13)	13091-4006	1
SCREW PAN HEAD 6X16 (Ref # 14)	220B0616	1
WASHER PLAIN 6MM (Ref # 15)	411B0600	1
WASHER SPRING 6MM (Ref # 16)	461F0600	1
COVER-TOOL CASE (Ref # 17)	14025-4022	1
BOLT-UPSET (Ref # 18)	112G0618	4
WASHER SPRING 6MM (Ref # 19)	461F0600	4
CASE,TOOL (Ref # 20)	32098-4002	1
WASHER 6.5X20X1.6T (Ref # 21)	92022-125	4
BAND,HEAD LAMP (Ref # 22)	92072-077	1
BRACKET (Ref # 23)	32065-4008	2