

1972 F8-A PARTS DIAGRAM

CRANKSHAFT/PISTON/ROTARY VALVE

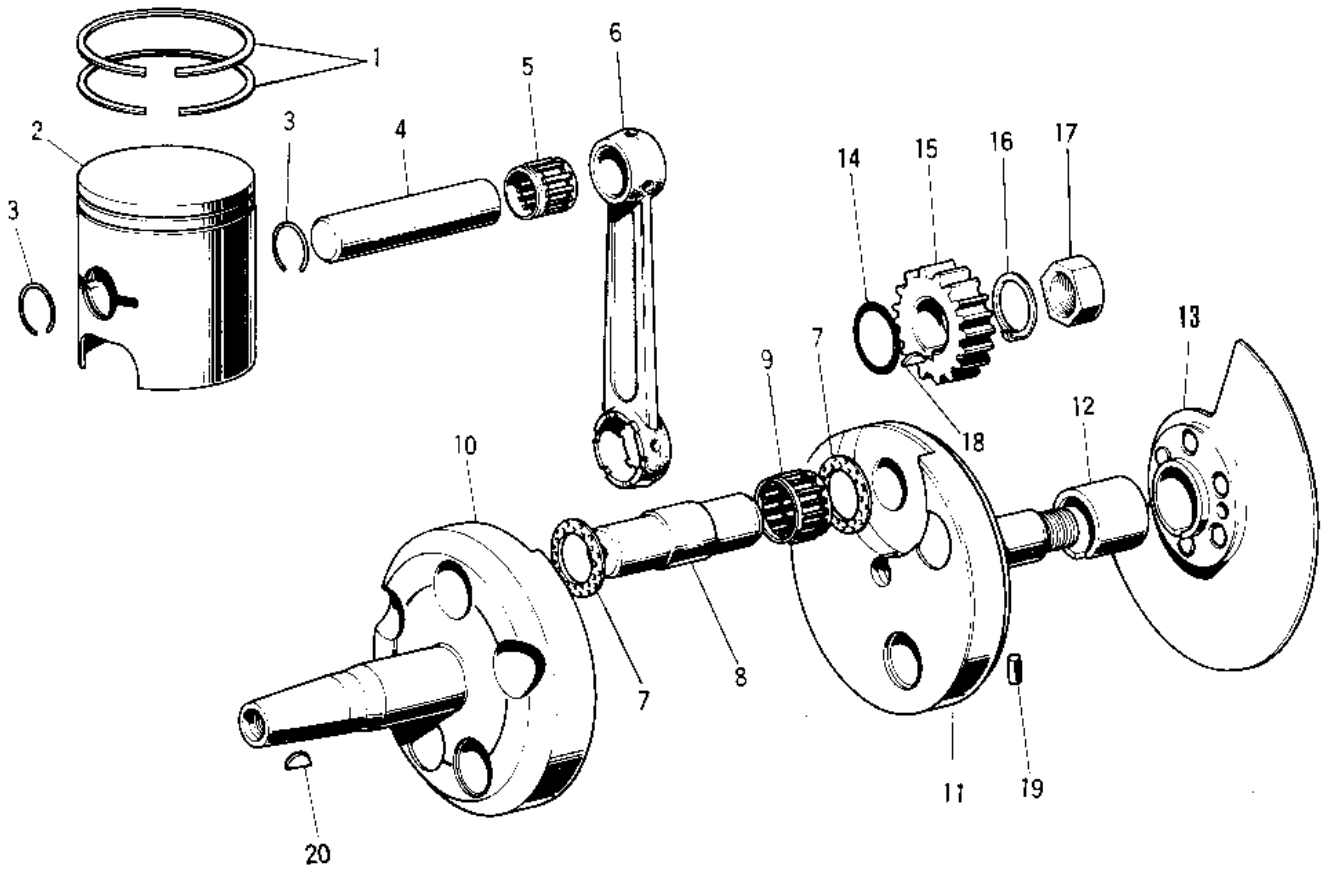

1972 F8-A PARTS LIST

CRANKSHAFT/PISTON/ROTARY VALVE

ITEM NAME	PART NUMBER	QUANTITY
-----------	-------------	----------