

# 1971 F5-A PARTS DIAGRAM

CLUTCH

116

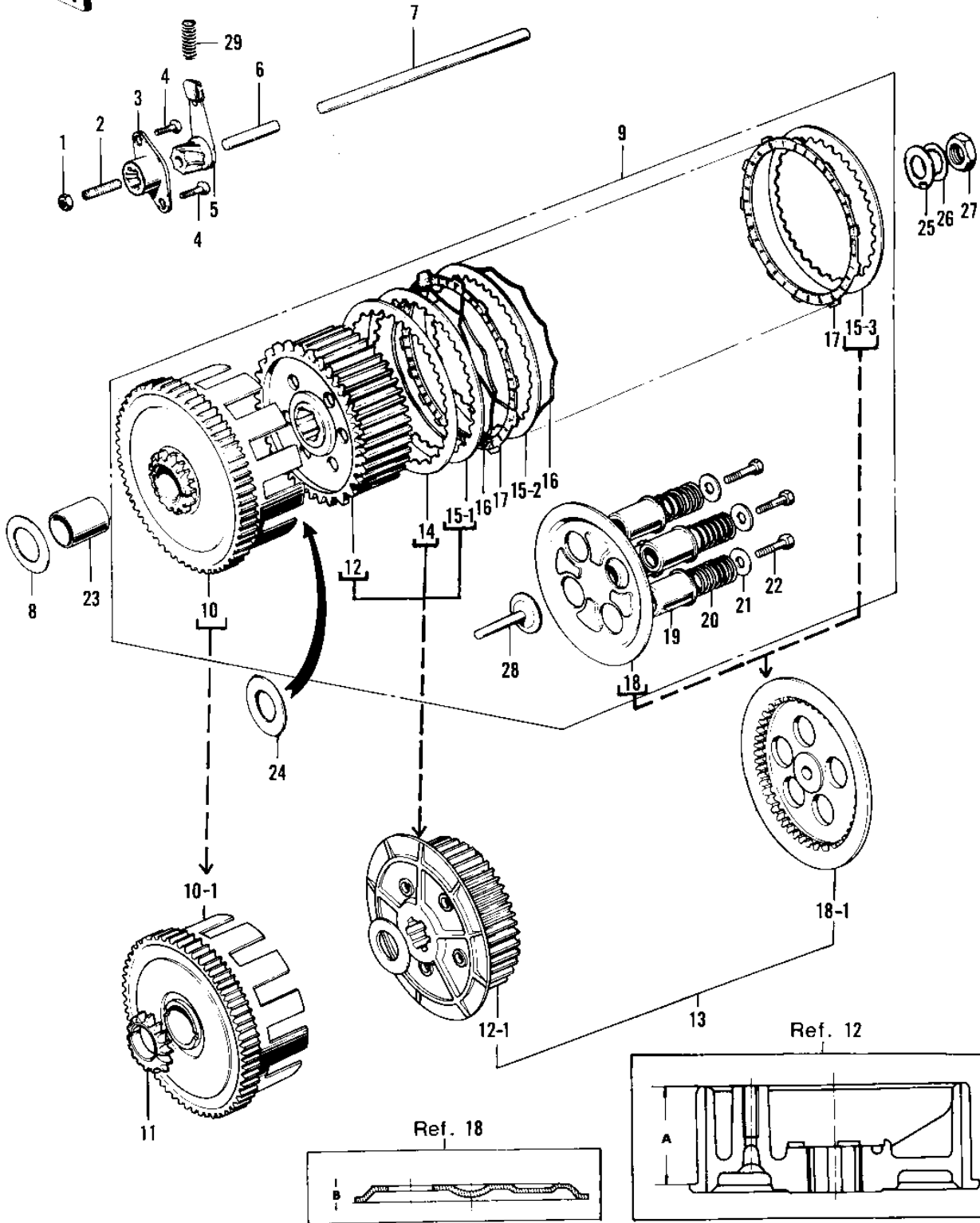

1006-1  
\*F9

# 1971 F5-A PARTS LIST

## CLUTCH

ITEM NAME	PART NUMBER	QUANTITY
NUT 6MM (Ref # 1)	311B0600	1
SCREW SLOTTED (Ref # 2)	291Z0622	1
SCREW-CLUTCH ADJUST (Ref # 2)	92014-011	1
RELEASE OUTER-CLUTCH (Ref # 3)	13118-005	1
SCREW PAN HEAD 6X14 (Ref # 4)	220B0614	1
RELEASE INNER-CLUTCH (Ref # 5)	13102-010	1
PUSH ROD-CLUTCH,SHORT (Ref # 6)	13116-013	1
PUSH ROD-CLUTCH,LONG (Ref # 7)	13116-012	1
WASHER TH 25.5X38X1T (Ref # 8)	92022-145	1
CLUTCH ASSY (Ref # 9)	13081-029	1
CLUTCH ASSY (Ref # 9)	13081-035	1
CLUTCH-ASSY (Ref # 9)	13081-042	1
UNAVAILABLE IN PRICE BOOK (Ref # 10)	13095-021	1
HOUSING-CLUTCH (Ref # 10-1)	13095-027	1
PINION-KICKSTARTER (Ref # 11)	13075-007	1
HUB CLUTCH (Ref # 12)	13087-014	1
HUB-CLUTCH (Ref # 12)	13087-030	1
HUB-CLUTCH (Ref # 12-1)	13087-030	1
HUB-CLUTCH (Ref # 12-1)	13087-030	1
HUB SET-CLUTCH (Ref # 13)	13084-005	1
PLATE CLUTCH OUTER (Ref # 14)	13090-011	1
PLATE CLUTCH STEEL (Ref # 15-1)	13089-013	1
PLATE CLUTCH STEEL (Ref # 15-2)	13089-013	1
PLATE CLUTCH STEEL (Ref # 15-3)	13089-013	1
RING-CLUTCH STEEL (Ref # 16)	13229-003	1
RING-CLUTCH STEEL (Ref # 16)	13229-003	1
PLATE-CLUTCH FRICTION (Ref # 17)	13088-021	1
PLATE-CLUTCH SPRING (Ref # 18)	13187-005	1
PLATE-CLUTCH SPRING (Ref # 18)	13187-005	1

## 1971 F5-A PARTS LIST

### CLUTCH

ITEM NAME	PART NUMBER	QUANTITY
PLATE-CLUTCH SPRING (Ref # 18-1)	13187-005	1
GUIDE CLUTCH SPRING (Ref # 19)	13092-005	1
SPRING CLUTCH (Ref # 20)	92081-042	1
HOLDER CL SPG6.5X20X2 (Ref # 21)	13091-009	1
BOLT-UPSET (Ref # 22)	112G0618	1
BUSHING 25X30X34L (Ref # 23)	92028-081	1
WASHER TH 25.5X47X2.5 (Ref # 24)	92026-022	1
WASHER PL 19X36.5X0.8 (Ref # 25)	92022-074	1
WASHER LOCK 18MM (Ref # 26)	463G1800	1
NUT 18MM (Ref # 27)	92015-019	1
PUSHER-CLTCH SPRG PLT (Ref # 28)	13116-011	1
SPRING-CLUTCH RELEASE (Ref # 29)	92081-069	1