

1972 Mach II PARTS DIAGRAM

CARBURETORS

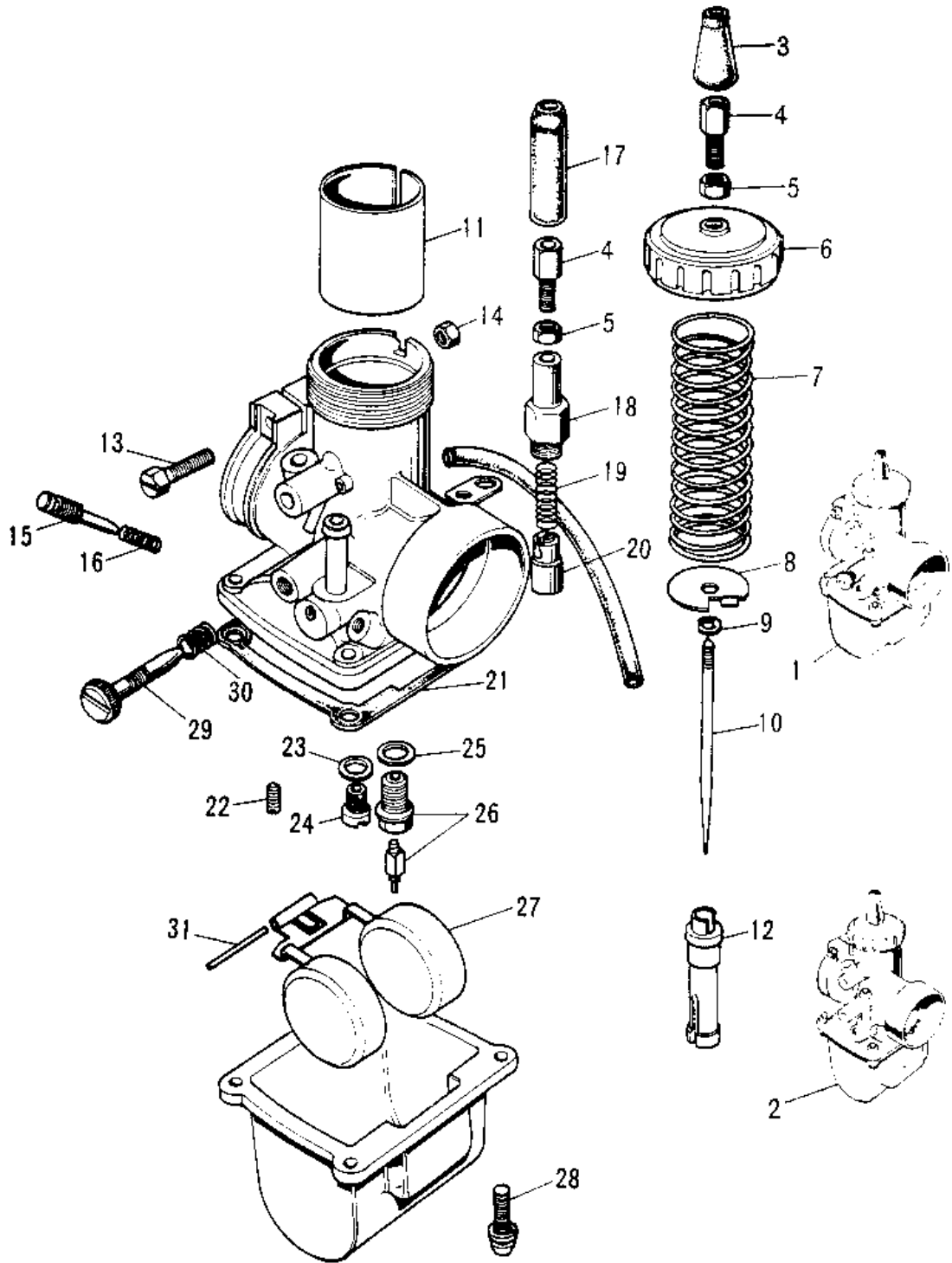

1972 Mach II PARTS LIST

CARBURETORS

ITEM NAME	PART NUMBER	QUANTITY
CARBURETOR ASY,R.HDCN (Ref # 1)	16001-146	2
CARBURETOR ASSY,L.H (Ref # 2)	16001-145	1
CAP,CARBURETOR (Ref # 3)	16036-007	3
ADJUSTER,CABLE (Ref # 4)	16002-017	6
NUT CABLE ADJUST LOCK (Ref # 5)	16003-004	6
CAP,MIXING CHAMBER (Ref # 6)	16004-025	3
SPRING THROTTLE VALVE (Ref # 7)	16006-014	3
SPRING SEAT,THRTL VL (Ref # 8)	16007-023	3
CIRCLIP (Ref # 9)	16008-010	3
JET NEEDLE 4EJ4 (Ref # 10)	16009-047	3
VALVE-THROTTLE,CA2.0 (Ref # 11)	16025-043	2
VALVE-THROTTLE,CA2.0 (Ref # 11)	16025-044	1
NEEDLE JET O-2 (Ref # 12)	16017-054	3
SCREW CLAMP (Ref # 13)	16010-004	3
NUT 6MM (Ref # 14)	311B0600	3
SCREW (Ref # 15)	16014-006	3
SPRING-THR STOP SCREW (Ref # 16)	16022-007	3
CAP CABLE ADJUST RUBB (Ref # 17)	16036-005	3
CAP STARTER PLUNGER (Ref # 18)	16012-008	3
SPRING-PLUNGER (Ref # 19)	16013-003	3
PLUNGER-ENRICHNER (Ref # 20)	16016-002	3
GASKET FLOAT CHAMBER (Ref # 21)	16019-013	3
JET-PILOT NO 25 (Ref # 22)	92064-032	3
WASHER MAIN JET (Ref # 23)	16034-001	3
MAIN JET NO 85R (Ref # 24)	92063-093	3
WASHER FLOAT VLV SEAT (Ref # 25)	16029-004	3
FLOAT VALVE ASSY (Ref # 26)	16030-005	3
FLOAT (Ref # 27)	16031-016	3
SCREW FLOAT CHAMBER (Ref # 28)	16033-009	12

1972 Mach II PARTS LIST

CARBURETORS

ITEM NAME	PART NUMBER	QUANTITY
SCREW-THROTTLE STOP (Ref # 29)	16021-013	3
SPRING THR STOP SCREW (Ref # 30)	16022-005	3
FLOAT PIN (Ref # 31)	16032-003	3