

# 1973 Mach II PARTS DIAGRAM

SIDE COVERS/OIL TANK/CHAIN COVER (S2)

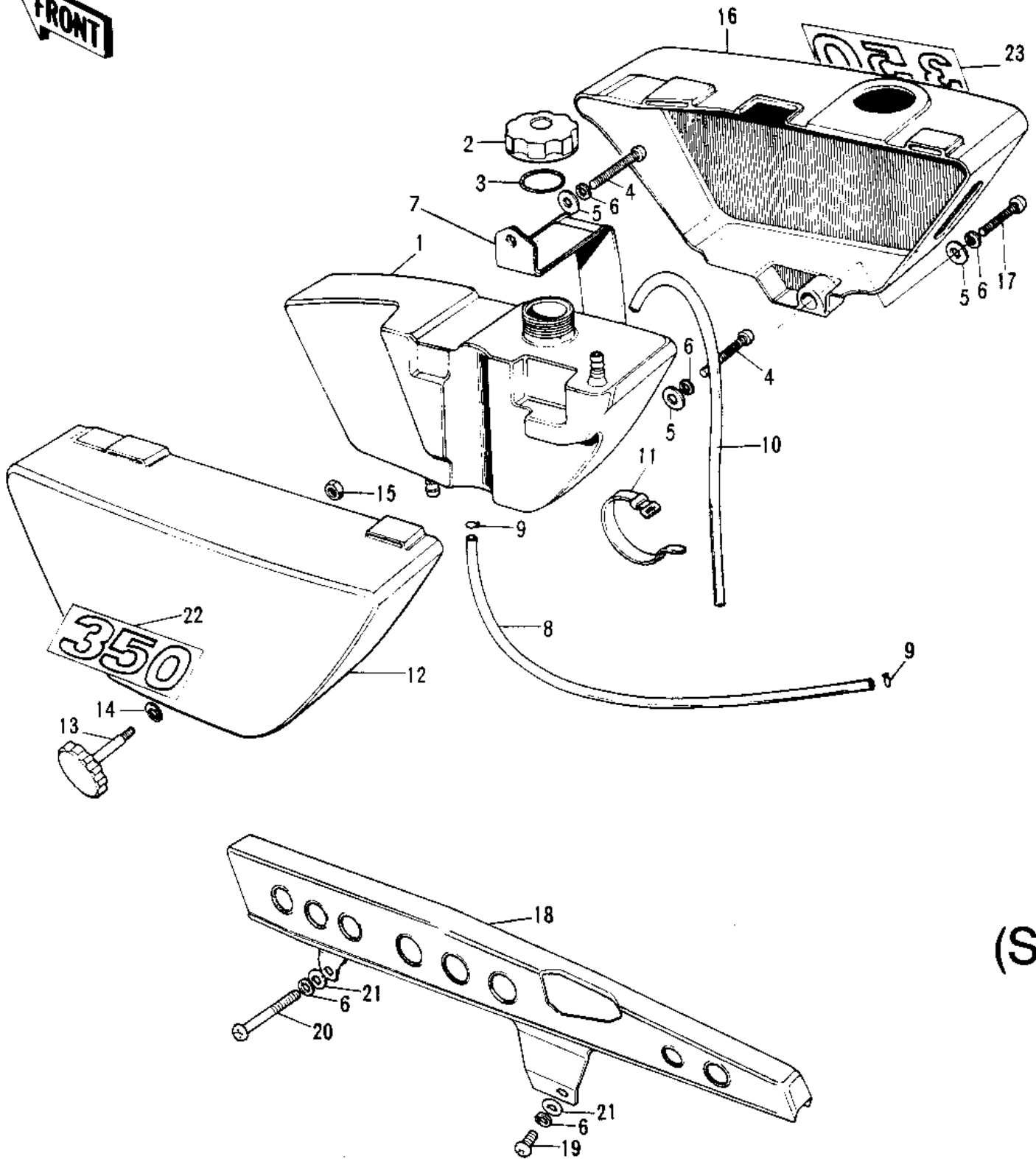

(S2)

## 1973 Mach II PARTS LIST

### SIDE COVERS/OIL TANK/CHAIN COVER (S2)

ITEM NAME	PART NUMBER	QUANTITY
TANK-OIL (Ref # 1)	52001-025	
CAP-OIL TANK (Ref # 2)	52003-015	
GASKET OIL TANK CAP (Ref # 3)	92065-020	
SCREW PAN HEAD 6X12 (Ref # 4)	220B0612	
WASHER PLAIN 6MM (Ref # 5)	411B0600	
WASHER SPRING 6MM (Ref # 6)	461F0600	
BAND-OIL TANK (Ref # 7)	52018-002	
PIPE-OIL (Ref # 8)	92059-072	
CLAMP FUEL PIPE (Ref # 9)	92037-010	
TUBE-VINYL,5X600 (Ref # 10)	700Q05600	
BAND,SHORT (Ref # 11)	92072-030	
COVER,L.H SIDE,C.RED (Ref # 12)	36001-039-68	
COVER,L.H SIDE,C.RED (Ref # 12)	36001-039-68	
KNOB (Ref # 13)	92077-020	
DAMPER RUBB SIDE COV (Ref # 14)	92075-041	
NUT 6MM (Ref # 15)	312B0600	
COVER,RH SIDE,C.RED (Ref # 16)	36007-031-68	
COVER,RH SIDE,C.RED (Ref # 16)	36007-031-68	
SCREW-PAN HEAD, 6X35 (Ref # 17)	220E0635	
CASE-CHAIN,FR BLACK (Ref # 18)	36014-040-21	
SCREW PAN HEAD 6X12 (Ref # 19)	220E0612	
SCREW PAN HEAD 6X55 (Ref # 20)	220E0655	
WASHER 6.5X20X1.6T (Ref # 21)	92022-125	
EMBLEM-L.H SIDE COVER (Ref # 22)	56018-084	
EMBLEM-R.H SIDE COVER (Ref # 23)	56018-086	