

# 1978 KZ400-C1 PARTS DIAGRAM

## CRANKCASE BOLT & STUD PATTERN

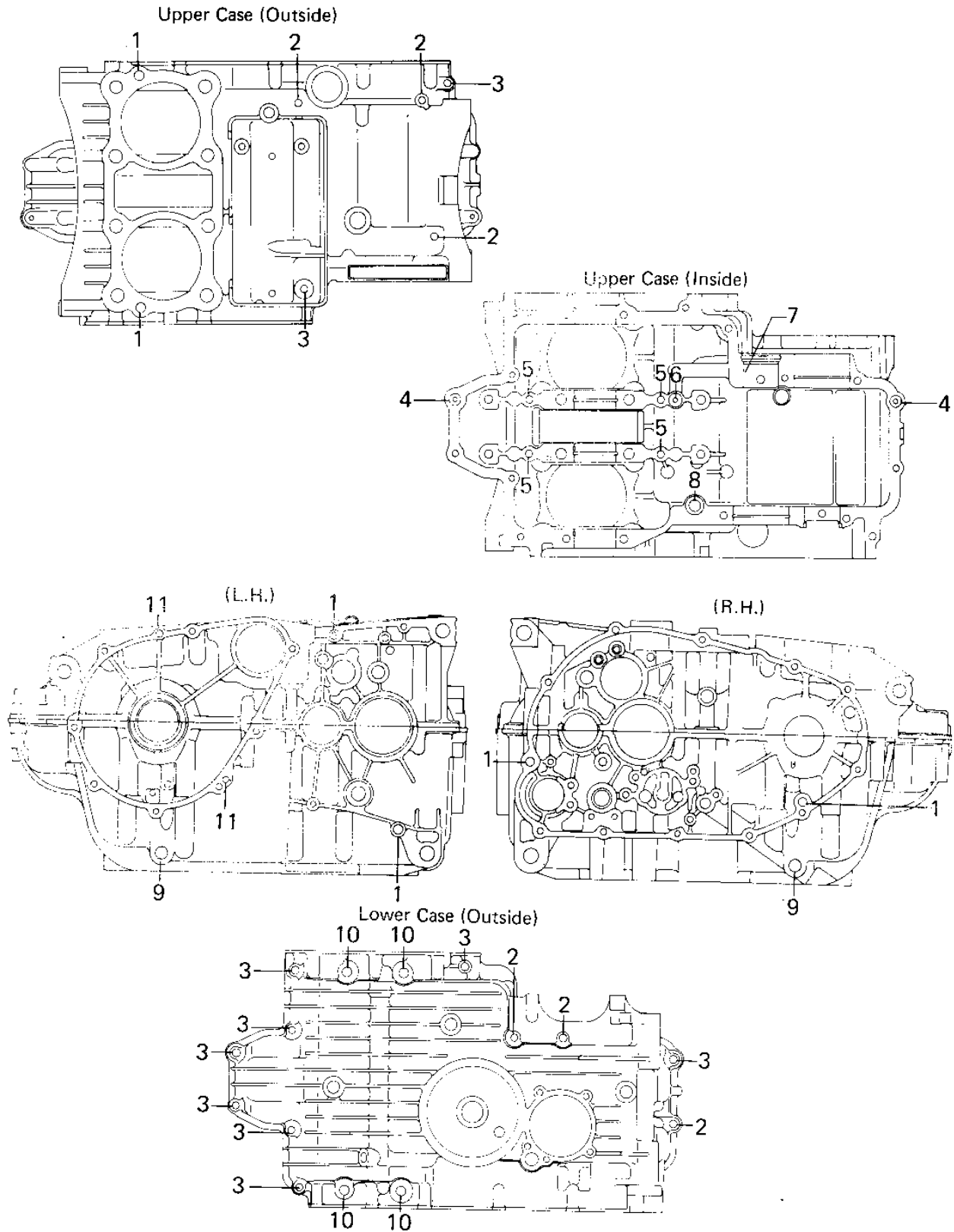

# 1978 KZ400-C1 PARTS LIST

## CRANKCASE BOLT & STUD PATTERN

ITEM NAME	PART NUMBER	QUANTITY
PIN-DOWEL (Ref # 1)	92042-007	6
BOLT-FLANGED,6X95 (Ref # 2)	130G0695	6
BOLT,HEX HEAD,6X54 (Ref # 3*)	92003-110	6
BOLT,HEX HEAD,6X54 (Ref # 3*)	92003-110	6
BOLT,HEX HEAD,6X54 (Ref # 3*)	92003-110	8
PIN,DOWEL,10X8.2X14 (Ref # 4*)	92043-1037	8
PIN,DOWEL,10X8.2X14 (Ref # 4*)	92043-1037	8
PIN,DOWEL,6X12 (Ref # 5*)	551A0612	8
PIN,DOWEL,6X12 (Ref # 5*)	551A0612	8
"O" RING (Ref # 6)	92055-074	1
NOZZLE,OIL BIAS (Ref # 7*)	92062-011	1
NOZZLE,OIL BIAS (Ref # 7*)	92062-011	1
O RING,0.D=18MM (Ref # 8)	92055-048	1
SET SCREW,PT 1/4 (Ref # 9*)	92013-010	1
SET SCREW,PT 1/4 (Ref # 9*)	92013-010	1
BOLT-FLANGED,8X95 (Ref # 10)	130P0895	4
PIN,DOWEL,6X12 (Ref # 11)	551A0612	2