

# 1978 Police 1000 PARTS DIAGRAM

CYLINDER/PISTONS/CRANKSHAFT (78 C1/C1A)

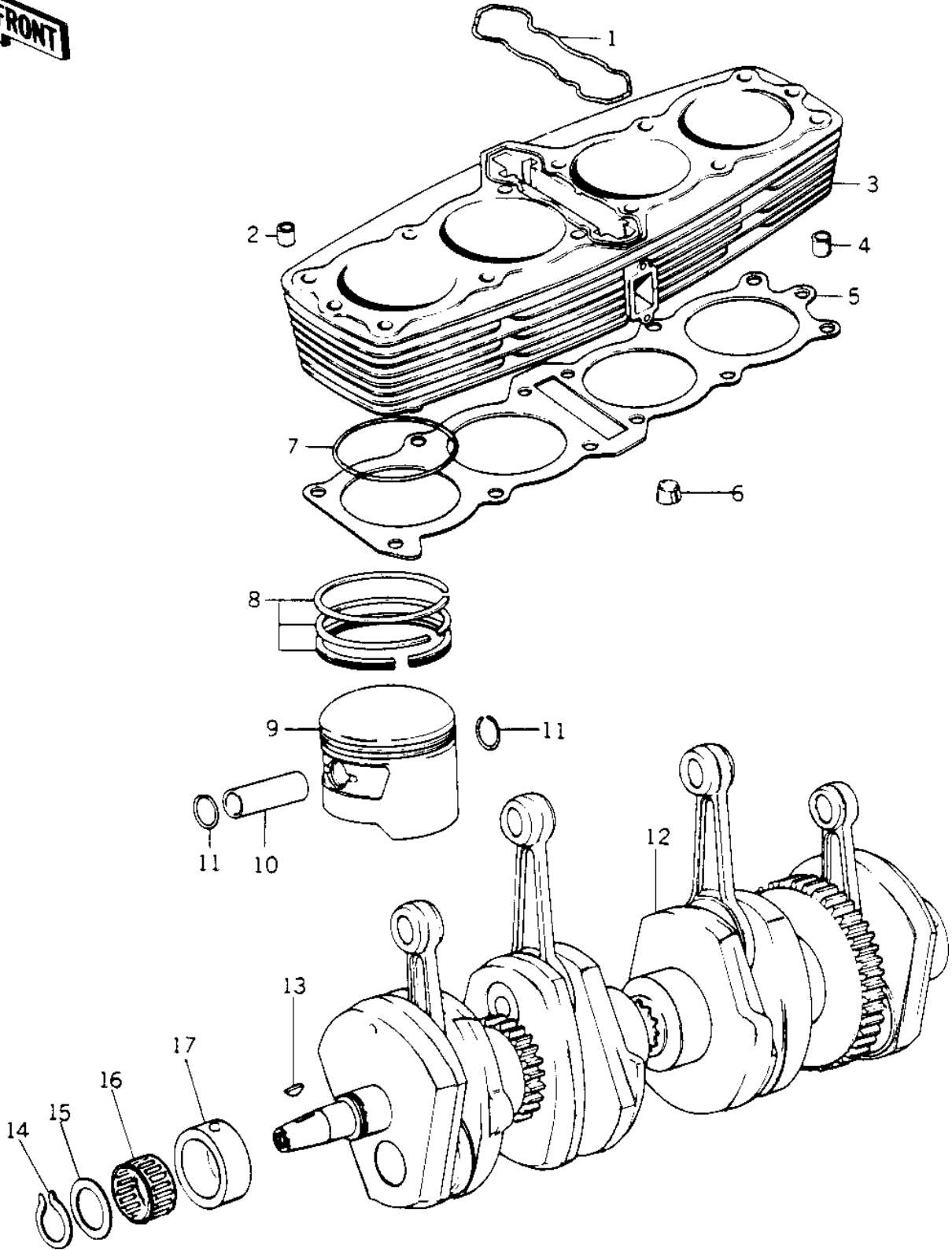

# 1978 Police 1000 PARTS LIST

CYLINDER/PISTONS/CRANKSHAFT ('78 C1/C1A)

ITEM NAME	PART NUMBER	QUANTITY
GASKET,CYLINDER RUBE (Ref # 1)	92055-062	1
PIN,DOWEL,10X8.2X14 (Ref # 2)	92043-1037	2
CYLINDER (Ref # 3)	11005-163-2H	1
PIN,11X14X12.3 (Ref # 4)	92043-1266	2
GASKET,CYLINDER BASE (Ref # 5)	11009-030	1
RUBBER PLUG,CYLINDER (Ref # 6)	92074-030	4
"O" RING,73MM (Ref # 7)	92055-054	4
RING SET,STD (Ref # 8)	13008-5012	4
RING SET,0.020"O/S (Ref # 8)	13025-5007	(4
RING SET,0.040"O/S (Ref # 8)	13024-5008	(4
PISTON,S.T.D (Ref # 9)	13001-1005	4
PISTON,0.020"O/S (Ref # 9)	13029-078	(4
PISTON,0.040"O/S (Ref # 9)	13027-1003	(4
PIN-PISTON (Ref # 10)	13002-022	4
CIRCLIP,PISTON PIN (Ref # 11)	92036-021	8
CRANKSHAFT ASSY (Ref # 12)	13031-056	1
CRANKSHAFT ASSY (Ref # 12)	13031-1006	1
WOODRUFF KEY (Ref # 13)	92038-001	1
CIRCLIP,30MM (Ref # 14)	480J3000	2
WASHER,THRUST (Ref # 15)	92026-079	2
BRG,N,PK304016.8X3 (Ref # 16)	92046-063	2
BUSHING,CRANKSHAFT (Ref # 17)	92028-121	2