

# 1980 Z1R PARTS DIAGRAM

BATTERY CASE/ELECTRO BRACKET ('80 D3)

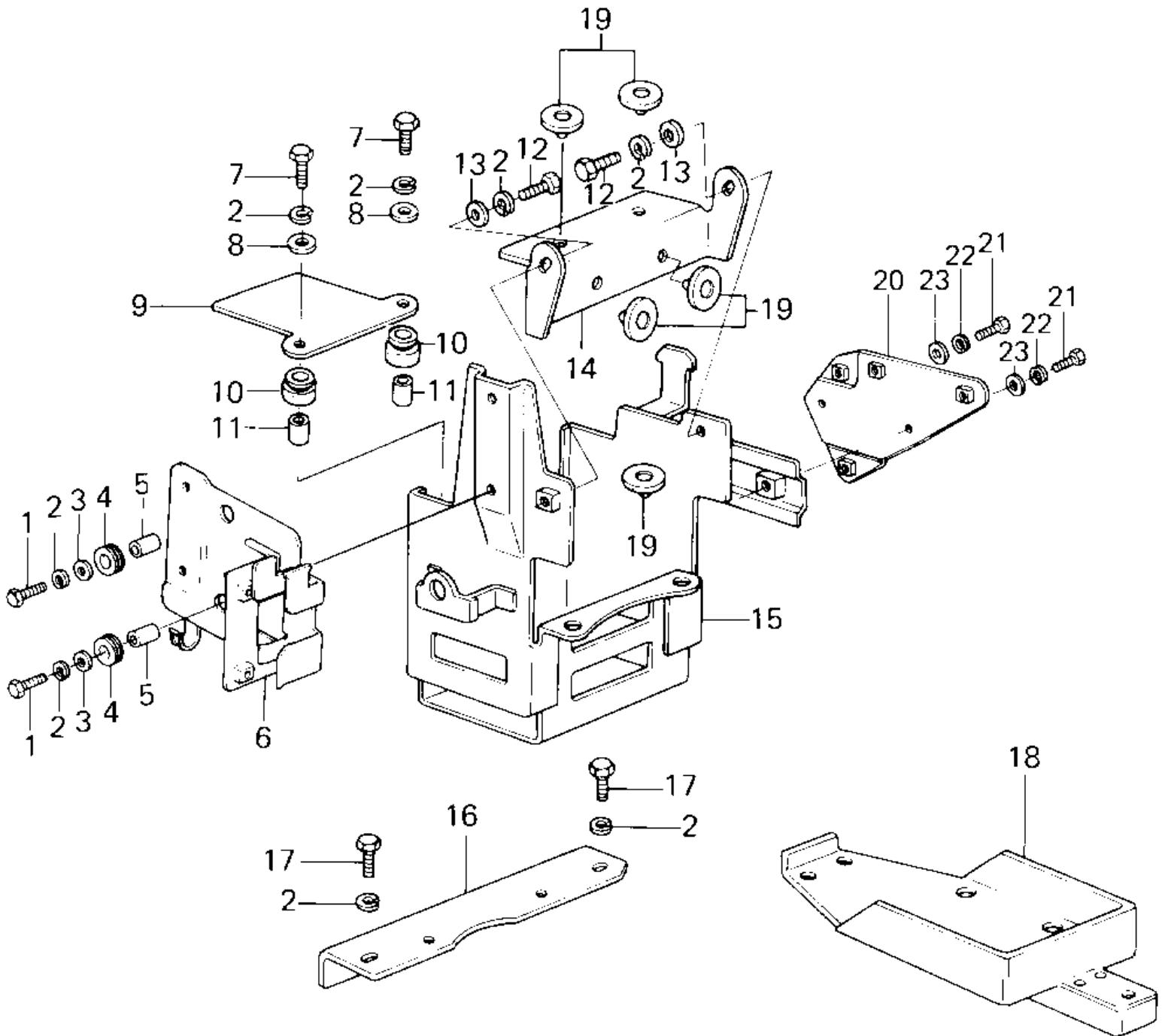

# 1980 Z1R PARTS LIST

BATTERY CASE/ELECTRO BRACKET ('80 D3)

ITEM NAME	PART NUMBER	QUANTITY
-----------	-------------	----------