

# 1983 KLT250 PARTS DIAGRAM

CHAIN CASE ('83 A2)

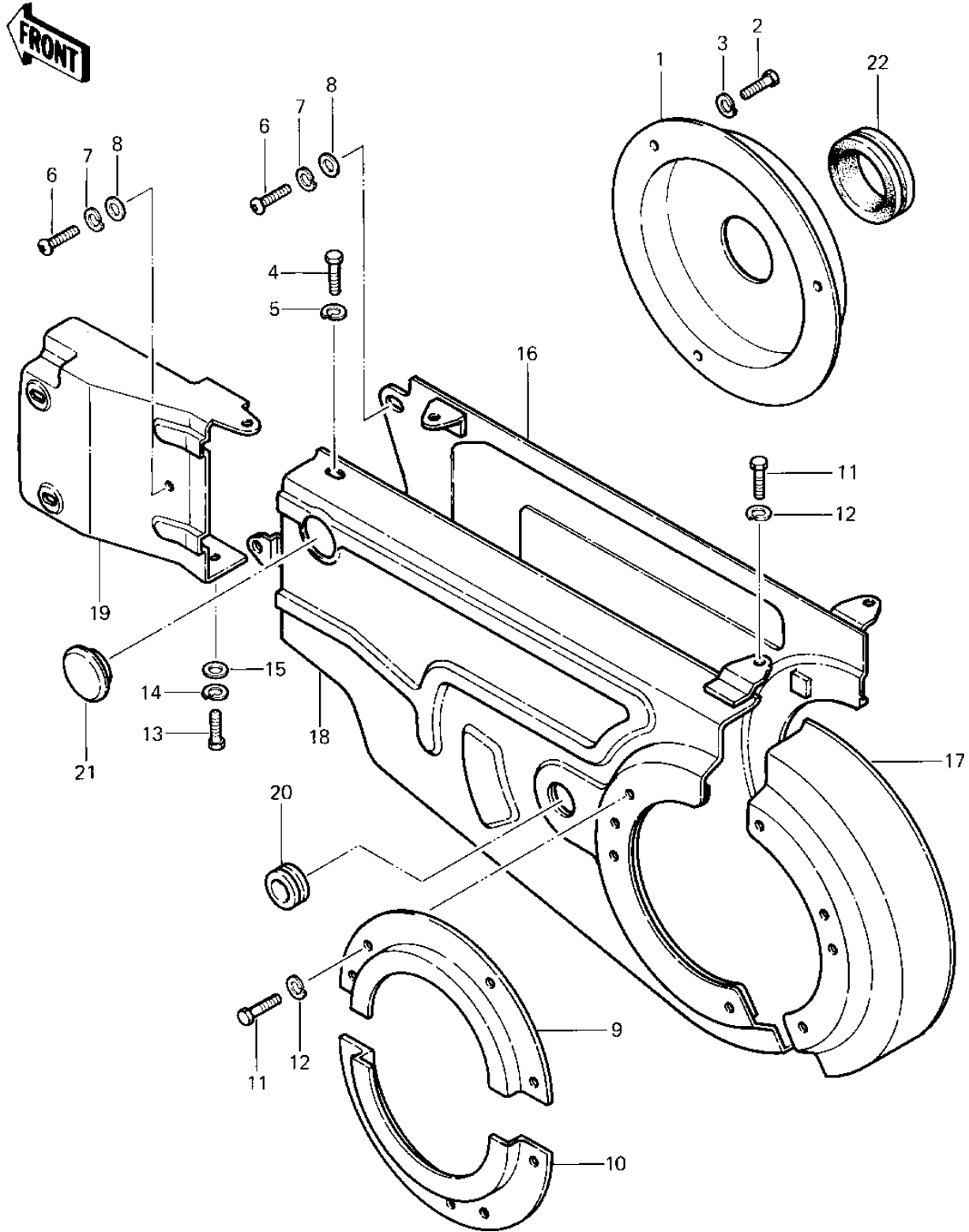

# 1983 KLT250 PARTS LIST

## CHAIN CASE ('83 A2)

ITEM NAME	PART NUMBER	QUANTITY
COVER,CHAIN CASE (Ref # 1)	14025-4018	1
BOLT-UPSET,6X12 (Ref # 2)	112G0612	3
WASHER SPRING 6MM (Ref # 3)	461F0600	3
BOLT-UPSET,6X16 (Ref # 4)	112G0616	1
WASHER SPRING 6MM (Ref # 5)	461F0600	1
SCREW PAN HEAD 6X12 (Ref # 6)	220B0612	5
WASHER SPRING 6MM (Ref # 7)	461F0600	5
WASHER PLAIN 6MM (Ref # 8)	410B0600	5
BRACKET,LARGE (Ref # 9)	11036-1454	1
BRACKET,SMALL (Ref # 10)	11036-1455	1
BOLT-UPSET,6X12 (Ref # 11)	112G0612	11
WASHER SPRING 6MM (Ref # 12)	461F0600	11
BOLT-UPSET 6X14 (Ref # 13)	112B0614	1
WASHER SPRING 6MM (Ref # 14)	461F0600	1
WASHER PLAIN 6MM (Ref # 15)	410B0600	1
CASE-CHAIN,INNER (Ref # 16)	36014-1041	1
CASE-CHAIN,RR (Ref # 17)	36014-1059	1
CASE-CHAIN,FR (Ref # 18)	36014-1060	1
CASE CHAIN,FR (Ref # 19)	36014-4011	1
GROMMET HARNESS 22MM (Ref # 20)	92071-012	1
PLUG CHAIN CASE (Ref # 21)	92074-004	1
SEAL (Ref # 22)	92093-4005	1