

1970 Mach III PARTS DIAGRAM

CRANKCASE ('69-72 H1/A/B/C)

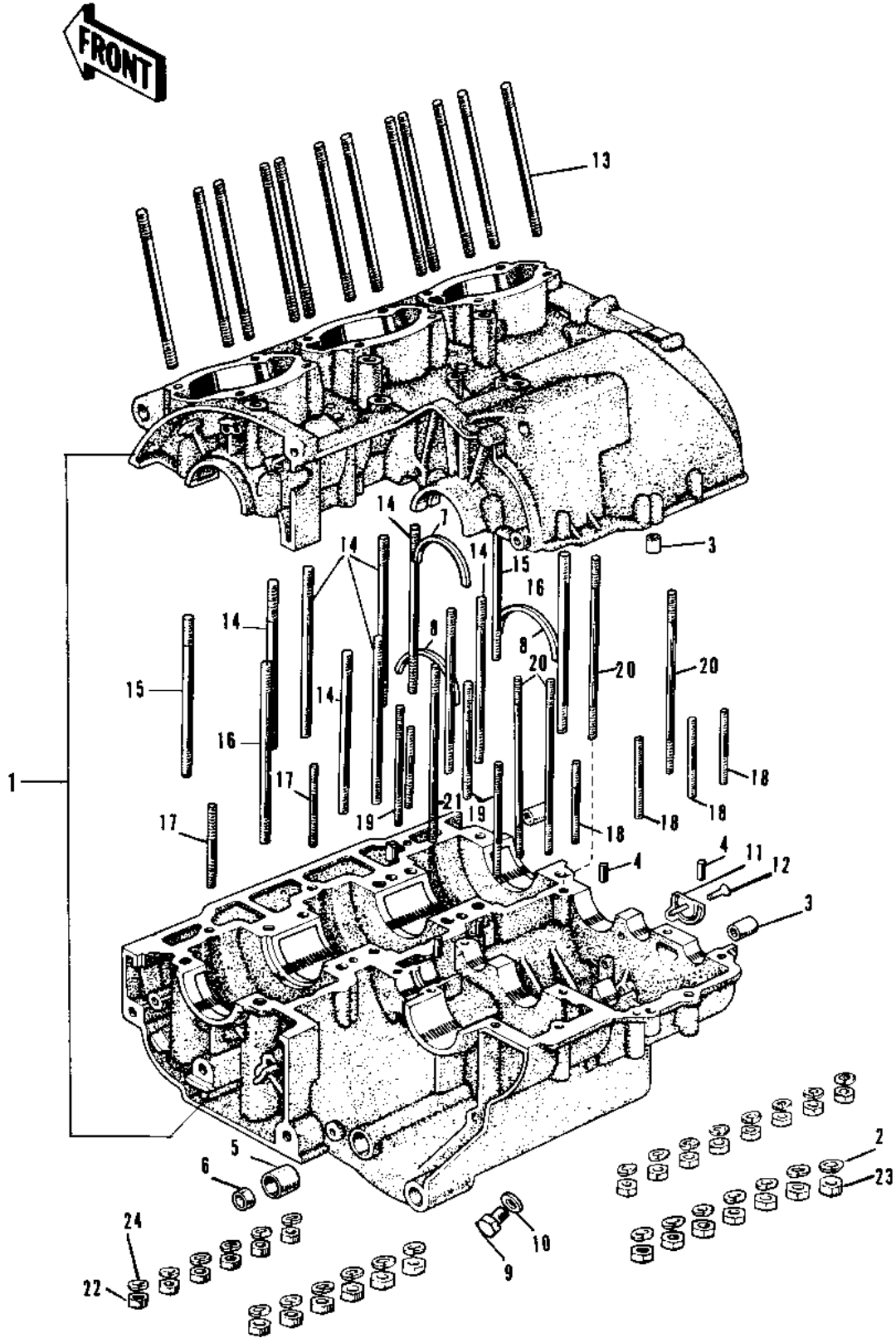

1970 Mach III PARTS LIST

CRANKCASE ('69-'72 H1/A/B/C)

ITEM NAME	PART NUMBER	QUANTITY
CRANKCASE SET (Ref # 1)	14001-030	1
WASHER SPRING 6MM (Ref # 2)	461F0600	15
PIN,DOWEL,10X8.2X14 (Ref # 3)	92043-1037	4
PIN DOWEL 6MM (Ref # 4)	92042-016	4
BUSH CHANGE PEDAL SHT (Ref # 5)	92028-071	1
OIL SEAL SB12205 (Ref # 6)	92049-004	1
RING,POSITION (Ref # 7)	14013-1004	1
RING BEARING SETTING (Ref # 8)	14013-004	2
PLUG OIL DRAIN (Ref # 9)	92067-001	1
GASKET CHECK VALVE (Ref # 10)	92065-058	1
RECEIVER OIL (Ref # 11)	14015-001	1
SCREW CNTSNK HD 6X16 (Ref # 12)	221B0616	1
STUD 8X75 (Ref # 13)	172G0875	12
STUD 10X60 (Ref # 14)	172G1060	8
STUD 10X75 (Ref # 15)	172G1075	2
STUD 10X90 (Ref # 16)	172G1090	2
STUD 6X20 (Ref # 17)	172G0620	1
STUD 6X22 (Ref # 17)	172G0622	3
STUD 6X35 (Ref # 18)	172G0635	4
STUD 6X50 (Ref # 19)	172G0650	3
STUD 6X75 (Ref # 20)	172G0675	4
STUD 6X85 (Ref # 21)	172G0685	1
NUT,10MM (Ref # 22)	317B1000	12
NUT 6MM (Ref # 23)	311B0600	15
WASHER SPRING 10MM (Ref # 24)	461F1000	12