

1969 Mach III PARTS DIAGRAM

AIR CLEANER (KH500-A8)

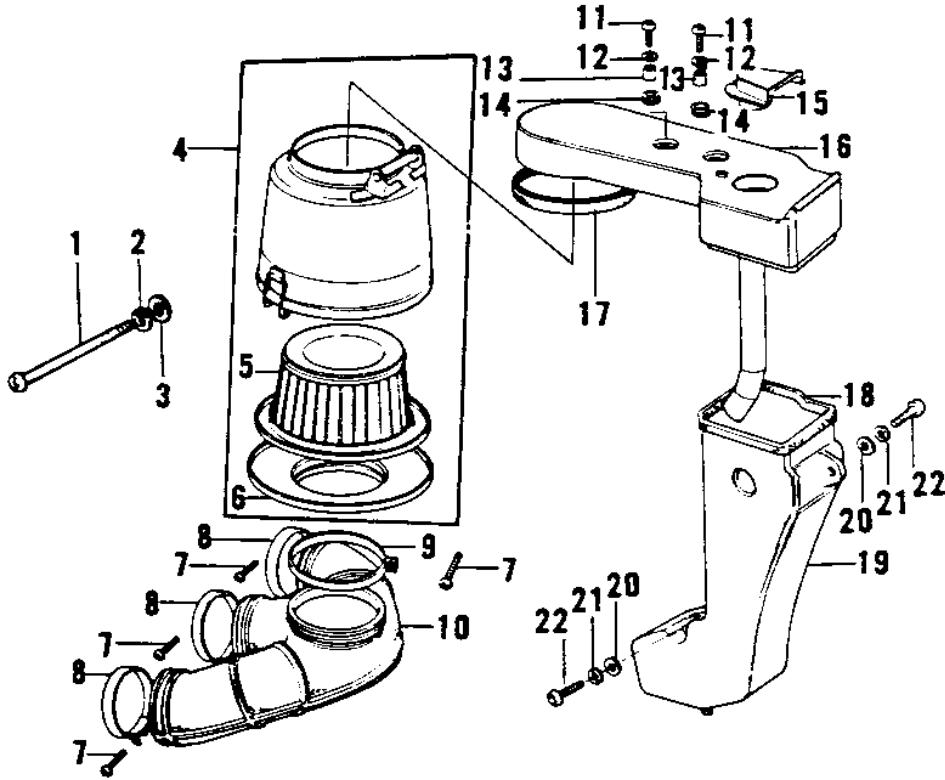

(KH500-

1969 Mach III PARTS LIST

AIR CLEANER (KH500-A8)

ITEM NAME	PART NUMBER	QUANTITY
SCREW PAN HEAD 6X110 (Ref # 1)	220B06110	1
WASHER SPRING 6MM (Ref # 2)	461F0600	1
WASHER PLAIN 6MM (Ref # 3)	410B0600	1
AIR CLEANER ASSY (Ref # 4)	11010-097	1
ELEMENT,AIR CLNR (Ref # 5)	11013-057	1
CAP AIR CLEANER (Ref # 6)	11012-011	1
SCREW-PAN-CROS,6X35,B (Ref # 7)	220C0635	4
CLAMP (Ref # 8)	92037-1326	3
CLAMP (Ref # 9)	92037-1326	3
PIPE ASSY-INLET (Ref # 10)	11015-033	1
SCREW PAN HEAD 6X45 (Ref # 11)	220B0645	2
WASHER 6.5X20X1.6T (Ref # 12)	92022-125	2
COLLAR-SILENCER (Ref # 13)	92027-149	2
DAMPER RUBBER (Ref # 14)	92075-118	2
CAP,AIR CLEANER (Ref # 15)	11012-062	1
SILENCER,AIR CLEANER (Ref # 16)	11012-061	1
GASKET,SILENCER (Ref # 17)	11017-009	1
GASKET,CLEANER BODY (Ref # 18)	11017-013	1
BODY,AIR CLEANER (Ref # 19)	11011-056	2
WASHER PLAIN (Ref # 20)	92022-024	2
WASHER SPRING 6MM (Ref # 21)	461F0600	2
BOLT-UPSET,6X16 (Ref # 22)	112G0616	2