

2001 1100 STX D.I. PARTS DIAGRAM

Ignition System(JT1100-F1)

E1830

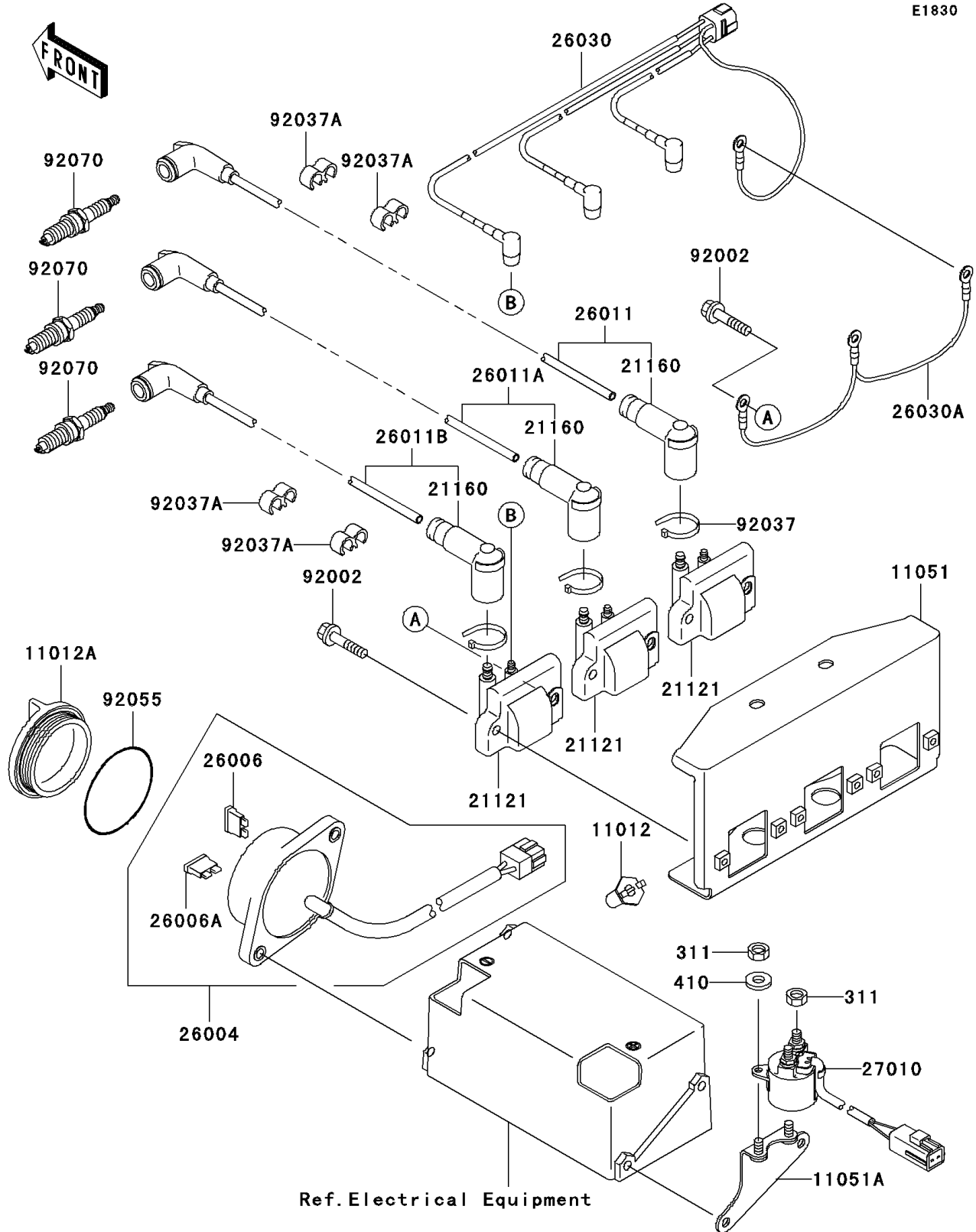

2001 1100 STX D.I. PARTS LIST

Ignition System(JT1100-F1)

ITEM NAME	PART NUMBER	QUANTITY
NUT-HEX,6MM (Ref # 311)	311R0600	4
WASHER-PLAIN-SMALL,6MM (Ref # 410)	410S0600	2
CAP,HOLDER (Ref # 11012)	11012-3768	3
CAP (Ref # 11012A)	11012-3791	1
BRACKET (Ref # 11051)	11051-3797	1
BRACKET (Ref # 11051A)	11051-3807	1
COIL-IGNITION (Ref # 21121)	21121-3718	3
CAP-ASSY-PLUG (Ref # 21160)	21160-3702	3
FUSE-ASSY (Ref # 26004)	26004-3722	1
FUSE,10A-R (Ref # 26006)	26006-1007	2
FUSE,20A-Y (Ref # 26006A)	26006-1051	2
WIRE-LEAD,#1 (Ref # 26011)	26011-3887	1
WIRE-LEAD,#2 (Ref # 26011A)	26011-3888	1
WIRE-LEAD,#3 (Ref # 26011B)	26011-3889	1
HARNESS (Ref # 26030)	26030-3730	1
HARNESS (Ref # 26030A)	26030-3737	1
SWITCH (Ref # 27010)	27010-3774	1
BOLT,6X25 (Ref # 92002)	92002-3714	6
CLAMP (Ref # 92037)	92037-1173	3
CLAMP,HOSE (Ref # 92037A)	92037-1603	4
RING-O (Ref # 92055)	92055-1292	1
PLUG-SPARK,PZFR7G-G(NGK),SOLID (Ref # 92070)	92070-3705	3