

1999 900 STX PARTS DIAGRAM

Jet Pump

E3191

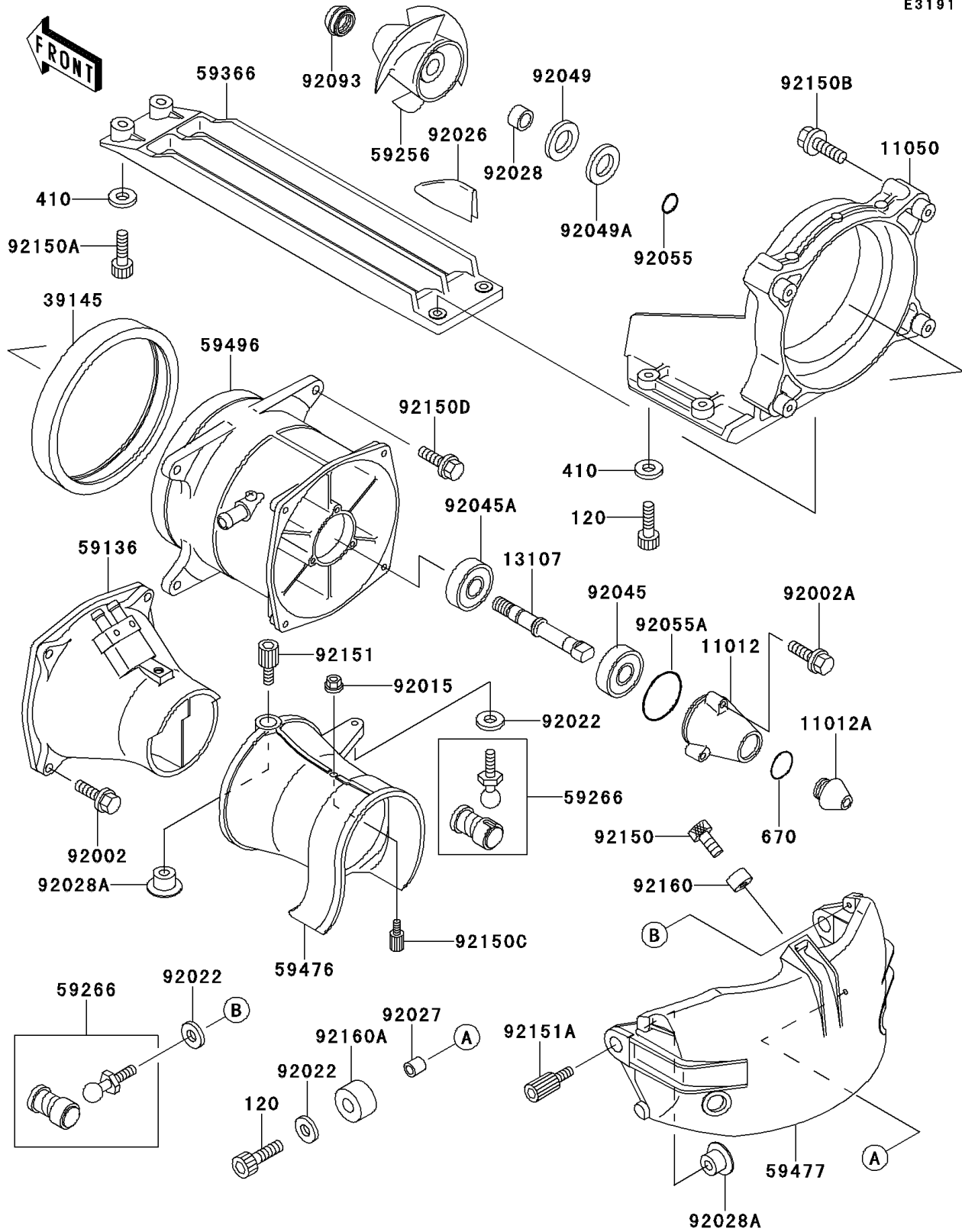

1999 900 STX PARTS LIST

Jet Pump

ITEM NAME	PART NUMBER	QUANTITY
BOLT-SOCKET,6X20 (Ref # 120)	120R0620	5
WASHER-PLAIN-SMALL,6MM (Ref # 410)	410S0600	8
O RING,20MM (Ref # 670)	670B2020	1
CAP (Ref # 11012)	11012-3771	1
CAP (Ref # 11012A)	11012-3772	1
BRACKET (Ref # 11050)	11050-3784	1
SHAFT,JETPUMP (Ref # 13107)	13107-3737	1
TRIM-SEAL (Ref # 39145)	39145-3742	1
NOZZLE-PUMP (Ref # 59136)	59136-3745	1
IMPELLER (Ref # 59256)	59256-3752	1
JOINT-BALL (Ref # 59266)	59266-3707	2
GRATE (Ref # 59366)	59366-3712	1
NOZZLE-STRG (Ref # 59476)	59476-3733	1
BUCKET-REVERSE (Ref # 59477)	59477-3707	1
VANE-GUIDE (Ref # 59496)	59496-3713	1
BOLT,6X35 (Ref # 92002)	92002-3715	4
BOLT,6X30 (Ref # 92002A)	92002-3726	3
NUT,6MM (Ref # 92015)	92015-3767	2
WASHER (Ref # 92022)	92022-567	3
SPACER (Ref # 92026)	92026-3731	3
COLLAR,6.2X10X10 (Ref # 92027)	92027-3705	1
BUSHING (Ref # 92028)	92028-3750	1
BUSHING (Ref # 92028A)	92028-3757	4
BEARING-BALL,62022RD (Ref # 92045)	92045-3721	1
BEARING-BALL,6303-132RD (Ref # 92045A)	92045-3722	1
SEAL-OIL (Ref # 92049)	92049-3717	1
SEAL-OIL (Ref # 92049A)	92049-3718	1
RING-O,OIL FILTER (Ref # 92055)	92055-1021	1
RING-O (Ref # 92055A)	92055-3741	1

1999 900 STX PARTS LIST

Jet Pump

ITEM NAME	PART NUMBER	QUANTITY
SEAL (Ref # 92093)	92093-3749	1
BOLT,SOCKET,6X10 (Ref # 92150)	92150-3759	1
BOLT,SOCKET,6X18 (Ref # 92150A)	92150-3775	4
BOLT,FLANGED,8X30 (Ref # 92150B)	92150-3803	2
BOLT (Ref # 92150C)	92150-3808	2
BOLT,8X30 (Ref # 92150D)	92150-3828	4
BOLT (Ref # 92151)	92151-3710	2
BOLT (Ref # 92151A)	92151-3716	2
DAMPER (Ref # 92160)	92160-3738	1
DAMPER (Ref # 92160A)	92160-3739	1