

# 2015 Vulcan® S PARTS DIAGRAM

Engine Cover(s)

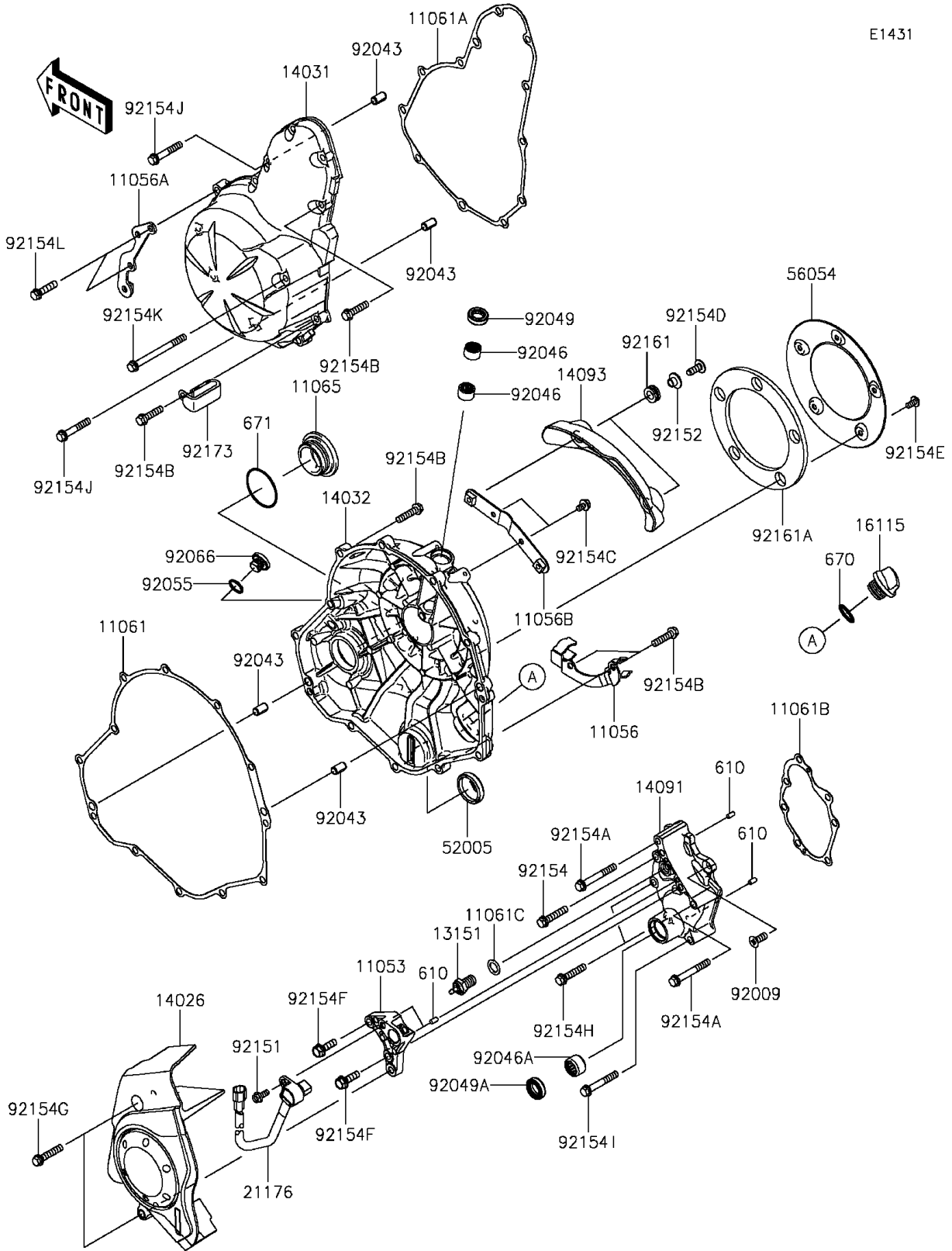

## 2015 Vulcan® S PARTS LIST

### Engine Cover(s)

ITEM NAME	PART NUMBER	QUANTITY
BRACKET (Ref # 11053)	11053-1739	1
BRACKET,BRAKE HOSE,RR (Ref # 11056)	11056-4259	1
BRACKET,RESERVOIR (Ref # 11056A)	11056-4435	1
BRACKET,RELEASE COVER (Ref # 11056B)	11056-7318	1
GASKET,CLUTCH COVER (Ref # 11061)	11061-0164	1
GASKET,GENERATOR COVER (Ref # 11061A)	11061-0165	1
GASKET,TRANSMISSION COVER (Ref # 11061B)	11061-0166	1
GASKET,10.5X16X1 (Ref # 11061C)	11061-0373	1
CAP (Ref # 11065)	11065-0281	1
SWITCH-COMP,NEUTRAL (Ref # 13151)	13151-1102	1
COVER-CHAIN (Ref # 14026)	14026-0092	1
COVER-GENERATOR (Ref # 14031)	14031-0599	1
COVER-CLUTCH (Ref # 14032)	14032-0591	1
COVER,TRANSMISSION (Ref # 14091)	14091-1673	1
COVER,CLUTCH RELEASE (Ref # 14093)	14093-0258	1
CAP-OIL FILLER (Ref # 16115)	16115-1053	1
SENSOR,SPEED (Ref # 21176)	21176-0065	1
GAUGE,OIL LEVEL (Ref # 52005)	52005-0071	1
MARK,CLUTCH COVER (Ref # 56054)	56054-1832	1
SCREW,6X16 (Ref # 92009)	92009-1360	1
PIN,6.2X8X14 (Ref # 92043)	92043-1263	4
BEARING-NEEDLE,HK1210FM (Ref # 92046)	92046-0034	2
BEARING-NEEDLE,HK1312 (Ref # 92046A)	92046-1148	1
SEAL-OIL,CLUTCH RELEASE (Ref # 92049)	92049-1475	1
SEAL-OIL,TC13225.5 (Ref # 92049A)	92049-1519	1
RING-O,13.0X1.9 (Ref # 92055)	92055-1011	1
PLUG,12X9.1 (Ref # 92066)	92066-0131	1
BOLT,FLANGED,5X12 (Ref # 92151)	92151-1305	1
COLLAR,6.3X8.3X7.2 (Ref # 92152)	92152-1602	2

## 2015 Vulcan® S PARTS LIST

### Engine Cover(s)

ITEM NAME	PART NUMBER	QUANTITY
BOLT,FLANGED,6X30 (Ref # 92154)	92154-0727	1
BOLT,FLANGED,6X45 (Ref # 92154A)	92154-0728	2
BOLT,FLANGED,6X25 (Ref # 92154B)	92154-0819	19
BOLT,FLANGED,5X8 (Ref # 92154C)	92154-0964	2
BOLT,SOCKET,6X16 (Ref # 92154D)	92154-1678	2
BOLT,SOCKET,5X10 (Ref # 92154E)	92154-1691	5
BOLT,FLANGED,6X20 (Ref # 92154F)	92154-1771	2
BOLT,FLANGED,6X30 (Ref # 92154G)	92154-1772	2
BOLT,FLANGED,6X30 (Ref # 92154H)	92154-1773	2
ROLLER,4X8 (Ref # 610)	610A0408	4
O RING,20MM (Ref # 670)	670B2020	1
O RING,40MM (Ref # 671)	671B2540	1
BOLT,FLANGED,6X40 (Ref # 92154I)	92154-1774	1
BOLT,FLANGED,6X35 (Ref # 92154J)	92154-1779	2
BOLT,FLANGED,6X70 (Ref # 92154K)	92154-1780	1
BOLT,FLANGED,6X25 (Ref # 92154L)	92154-1785	2
DAMPER,8.3X16X6.4 (Ref # 92161)	92161-0664	2
DAMPER (Ref # 92161A)	92161-1767	1
CLAMP (Ref # 92173)	92173-0725	1