

2009 Ninja ZX-6R Monster Energy PARTS DIAGRAM

Seat(R9FA)

F2510A

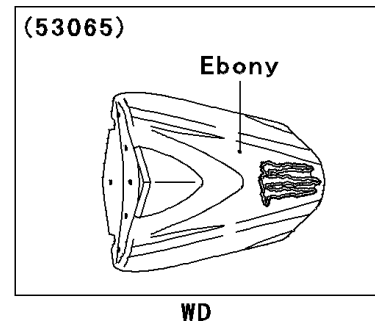
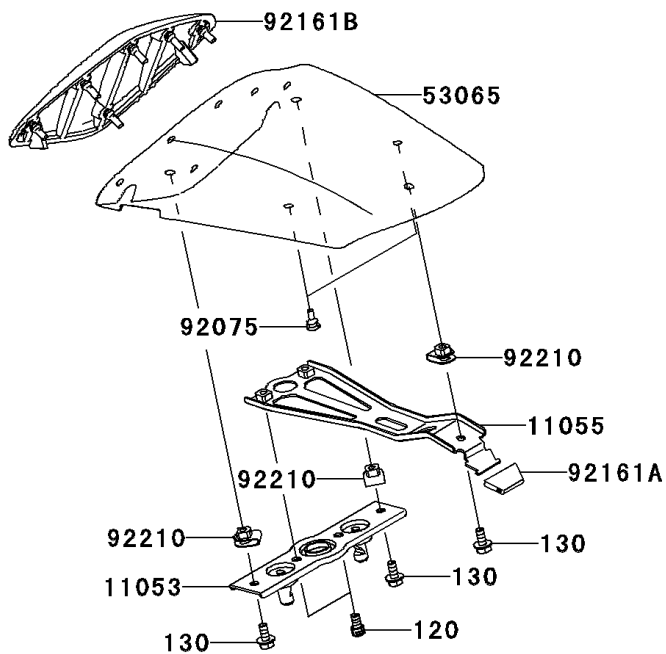
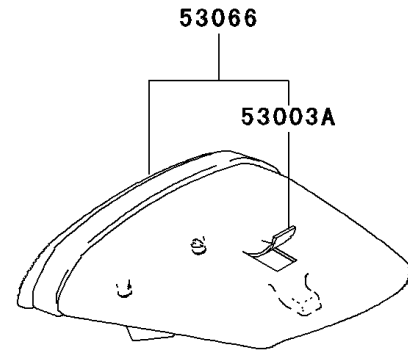
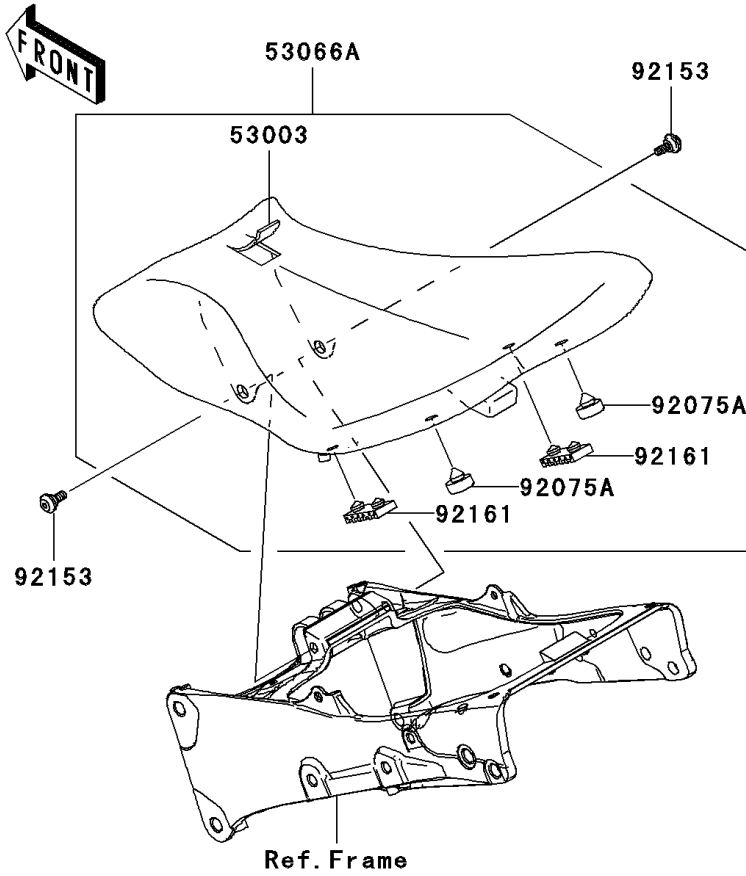

2009 Ninja ZX-6R Monster Energy PARTS LIST

Seat(R9FA)

ITEM NAME	PART NUMBER	QUANTITY
-----------	-------------	----------