

2012 MULE™ 610 4x4 XC CAMO PARTS DIAGRAM

Carrier(s)

F2520

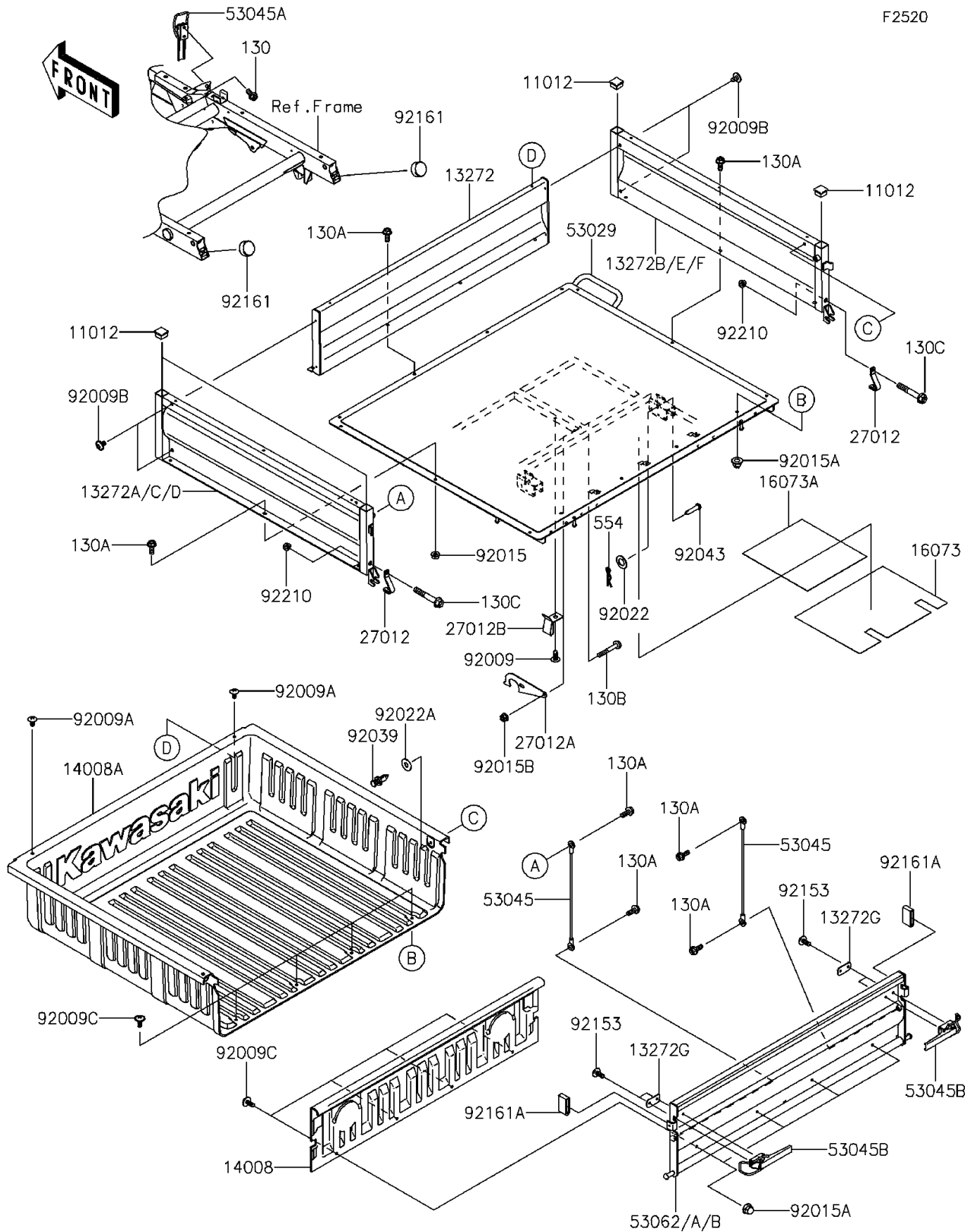

2012 MULE™ 610 4x4 XC CAMO PARTS LIST

Carrier(s)

ITEM NAME	PART NUMBER	QUANTITY
CAP (Ref # 11012)	11012-1784	4
PLATE,CARRIER,SIDE,FR,BLACK (Ref # 13272)	13272-0541-10	1
PLATE,CARRIER,LH,CAMOUFLAGE (Ref # 13272C)	13272-1138-16N	1
PLATE,CARRIER,RH,CAMOUFLAGE (Ref # 13272E)	13272-1139-16N	1
PLATE (Ref # 13272G)	13272-7516	2
LINER,TAILGATE (Ref # 14008)	14008-0019	1
LINER,CARRIER BASE (Ref # 14008A)	14008-0020	1
INSULATOR,CARRIER (Ref # 16073)	16073-0040	1
INSULATOR (Ref # 16073A)	16073-7501	1
HOOK,TAIL GATE (Ref # 27012)	27012-0022	2
HOOK (Ref # 27012A)	27012-0044	1
HOOK,CARRIER (Ref # 27012B)	27012-1445	1
CARRIER,BLACK (Ref # 53029)	53029-0089-10	1
HOOK-ASSY,TAIL GATE (Ref # 53045)	53045-0006	2
HOOK-ASSY (Ref # 53045A)	53045-1063	1
HOOK-ASSY (Ref # 53045B)	53045-7503	2
GATE-TAIL,CAMOUFLAGE (Ref # 53062A)	53062-0304-16N	1
SCREW,TAPPING,6X16 (Ref # 92009)	92009-1166	1
SCREW,6X12 (Ref # 92009A)	92009-1480	2
SCREW,6X10 (Ref # 92009B)	92009-1661	4
SCREW,6X14 (Ref # 92009C)	92009-1662	8
NUT,FLANGED,6MM,BLACK (Ref # 92015)	92015-1233	10
NUT,LOCK 6MM (Ref # 92015A)	92015-1262	8
NUT,LOCK,FLANGED,6MM (Ref # 92015B)	92015-1675	1
WASHER,12.5X22X1.2 (Ref # 92022)	92022-072	2
WASHER,8.5X20X1.6,BLACK (Ref # 92022A)	92022-1317	2
RIVET (Ref # 92039)	92039-1229	2
PIN,12X54 (Ref # 92043)	92043-1451	2
BOLT,SOCKET,6X14 (Ref # 92153)	92153-1361	4

2012 MULE™ 610 4x4 XC CAMO PARTS LIST

Carrier(s)

ITEM NAME	PART NUMBER	QUANTITY
DAMPER,SEAT (Ref # 92161)	92161-1065	2
DAMPER (Ref # 92161A)	92161-7519	2
NUT,FLANGED,8MM (Ref # 92210)	92210-0555	2
BOLT-FLANGED,6X14 (Ref # 130)	130BA0614	2
BOLT-FLANGED,6X16 (Ref # 130A)	130BB0616	14
BOLT-FLANGED,6X40 (Ref # 130B)	130BB0640	1
BOLT-FLANGED,8X50 (Ref # 130C)	130BB0850	2
PIN-SNAP,12MM (Ref # 554)	554DA1200	2