

# 2013 MULE™ 610 4x4 XC Realtree APG HD PARTS DIAGRAM

## Chassis Electrical Equipment

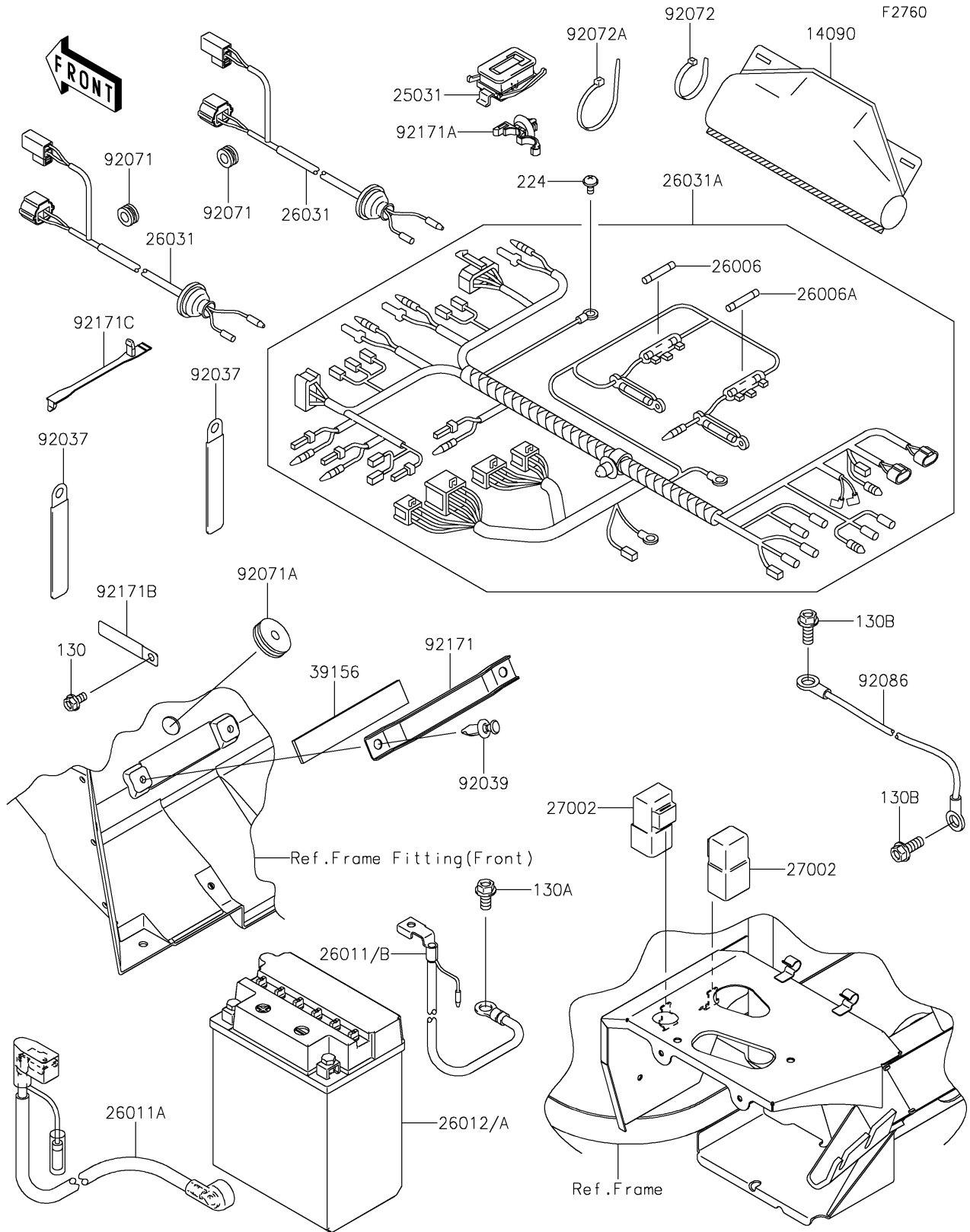

# 2013 MULE™ 610 4x4 XC Realtree APG HD PARTS LIST

## Chassis Electrical Equipment

ITEM NAME	PART NUMBER	QUANTITY
COVER,COUPLER (Ref # 14090)	14090-1331	3
METER-ASSY (Ref # 25031)	25031-0397	1
FUSE,GLASS TUBE,6.4X30,10A,YEL (Ref # 26006)	26006-1002	2
FUSE,30A,L=32 (Ref # 26006A)	26006-1065	2
WIRE-LEAD,BATTERY(+) (Ref # 26011A)	26011-0048	1
WIRE-LEAD,BATTERY(-) (Ref # 26011B)	26011-0738	1
BATTERY,YB14A-A2,12V 14AH (Ref # 26012A)	26012-1446	1
HARNESS,HEAD LAMP (Ref # 26031)	26031-0155	2
HARNESS,MAIN (Ref # 26031A)	26031-0718	1
RELAY-ASSY (Ref # 27002)	27002-1088	2
PAD (Ref # 39156)	39156-0063	1
CLAMP,HARNESS,L=100 (Ref # 92037)	92037-1636	2
RIVET (Ref # 92039)	92039-1229	2
GROMMET (Ref # 92071)	92071-1128	2
GROMMET (Ref # 92071A)	92071-1136	1
BAND,L=123 (Ref # 92072)	92072-030	3
BAND,L=188 (Ref # 92072A)	92072-1239	6
WIRE (Ref # 92086)	92086-1054	1
CLAMP (Ref # 92171)	92171-0301	1
CLAMP (Ref # 92171A)	92171-0453	5
CLAMP,L=60 (Ref # 92171B)	92171-0652	1
CLAMP (Ref # 92171C)	92171-1365	1
BOLT-FLANGED,6X12 (Ref # 130)	130AA0612	1
BOLT-FLANGED,8X16 (Ref # 130A)	130BA0816	1
BOLT-FLANGED,8X20 (Ref # 130B)	130BB0820	2
SCREW-PAN-WP-CROS,5X8 (Ref # 224)	224AA0508	1