

2019 KLX®150L PARTS DIAGRAM

Air Cleaner

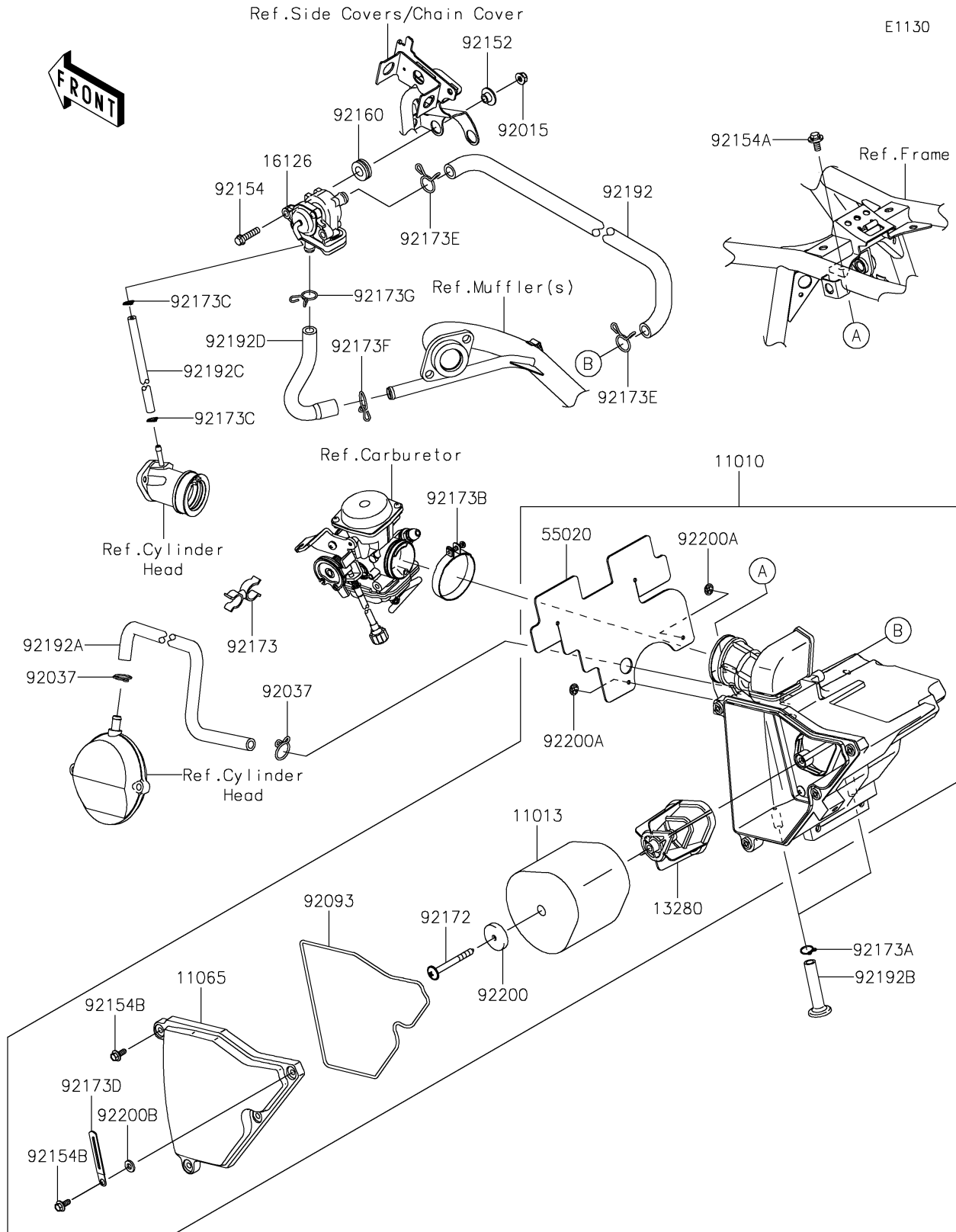

2019 KLX®150L PARTS LIST

Air Cleaner

ITEM NAME	PART NUMBER	QUANTITY
FILTER-ASSY-AIR (Ref # 11010)	11010-0830	1
ELEMENT-AIR FILTER (Ref # 11013)	11013-0796	1
CAP (Ref # 11065)	11065-0895	1
HOLDER (Ref # 13280)	13280-0831	1
VALVE,AIR SWITCH (Ref # 16126)	16126-0715	1
GUARD (Ref # 55020)	55020-1861	1
NUT,FLANGED,6MM (Ref # 92015)	92015-1367	2
CLAMP,12.5MM (Ref # 92037)	92037-1271	2
SEAL (Ref # 92093)	92093-0655	1
COLLAR (Ref # 92152)	92152-0854	2
BOLT,FLANGED,6X25 (Ref # 92154)	92154-1156	2
BOLT,FLANGED,6X14 (Ref # 92154A)	92154-1231	1
BOLT,FLANGED,5X14 (Ref # 92154B)	92154-1637	4
DAMPER (Ref # 92160)	92160-1278	2
SCREW,6X60 (Ref # 92172)	92172-0915	1
CLAMP (Ref # 92173)	92173-0081	1
CLAMP,11.6MM (Ref # 92173A)	92173-0179	2
CLAMP (Ref # 92173B)	92173-1104	1
CLAMP (Ref # 92173C)	92173-1190	2
CLAMP (Ref # 92173D)	92173-1424	1
CLAMP (Ref # 92173E)	92173-1563	2
CLAMP (Ref # 92173F)	92173-1879	1
CLAMP (Ref # 92173G)	92173-1880	1
TUBE,ASV-AIR CLEANER (Ref # 92192)	92192-0474	1
TUBE,BREATHER (Ref # 92192A)	92192-0839	1
TUBE,A/C-DRAIN (Ref # 92192B)	92192-0943	2
TUBE,CARB. HOLDER-ASV (Ref # 92192C)	92192-1242	1
TUBE,ASV-EX PIPE (Ref # 92192D)	92192-1337	1
WASHER (Ref # 92200)	92200-1692	1

2019 KLX®150L PARTS LIST

Air Cleaner

ITEM NAME	PART NUMBER	QUANTITY
WASHER (Ref # 92200A)	92200-1693	2
WASHER (Ref # 92200B)	92200-1695	1