

2010 Jet Ski® Ultra® 260LX PARTS DIAGRAM

Intake Silencer

E1130

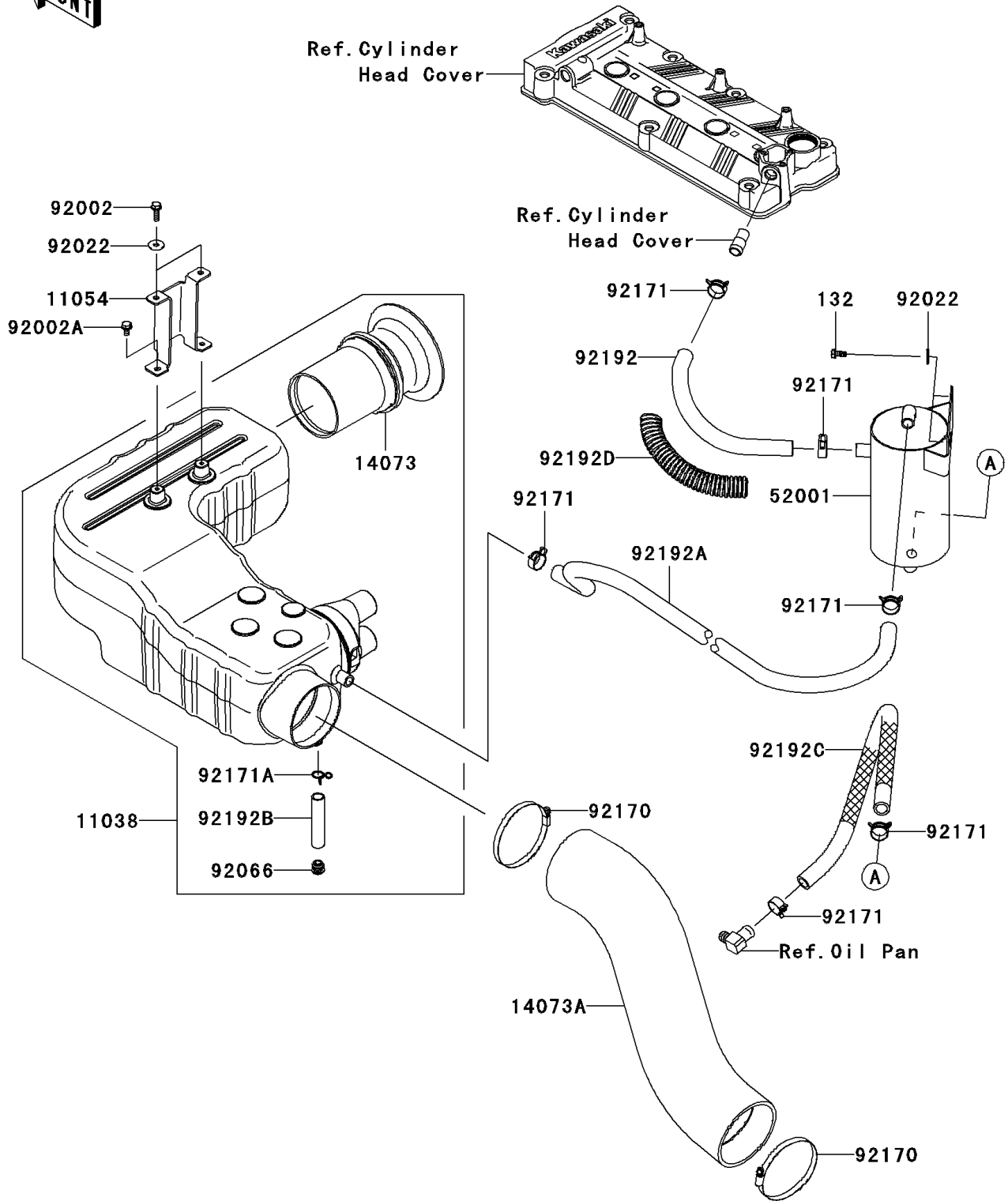

2010 Jet Ski® Ultra® 260LX PARTS LIST

Intake Silencer

ITEM NAME	PART NUMBER	QUANTITY
CASE-ASSY-AIR FILTER (Ref # 11038)	11038-3709	1
BRACKET,AIR BOX (Ref # 11054)	11054-3745	1
DUCT,INLET (Ref # 14073)	14073-3826	1
DUCT,A/C-S/C (Ref # 14073A)	14073-3833	1
TANK-OIL,SEPARATOR (Ref # 52001)	52001-3741	1
BOLT,6X20 (Ref # 92002)	92002-3755	2
BOLT,6X12 (Ref # 92002A)	92002-3763	2
WASHER,6.5X20X1.5 (Ref # 92022)	92022-3710	4
PLUG,DRAIN (Ref # 92066)	92066-3792	1
CLAMP (Ref # 92170)	92170-3760	2
CLAMP,TUBE (Ref # 92171)	92171-3710	6
CLAMP,15.75MM (Ref # 92171A)	92171-3721	1
TUBE,HEAD-OIL TANK (Ref # 92192)	92192-3768	1
TUBE,OIL TANK-A/C (Ref # 92192A)	92192-3769	1
TUBE,12.7X15.9X75 (Ref # 92192B)	92192-3794	1
TUBE,OIL TANK-OIL PAN (Ref # 92192C)	92192-3807	1
TUBE,CORRUGATED,L=160 (Ref # 92192D)	92192-3832	1
BOLT-FLANGED-SMALL,6X14 (Ref # 132)	132BD0614	2