

2004 Vulcan 1600 Mean Streak PARTS DIAGRAM

Frame Fittings

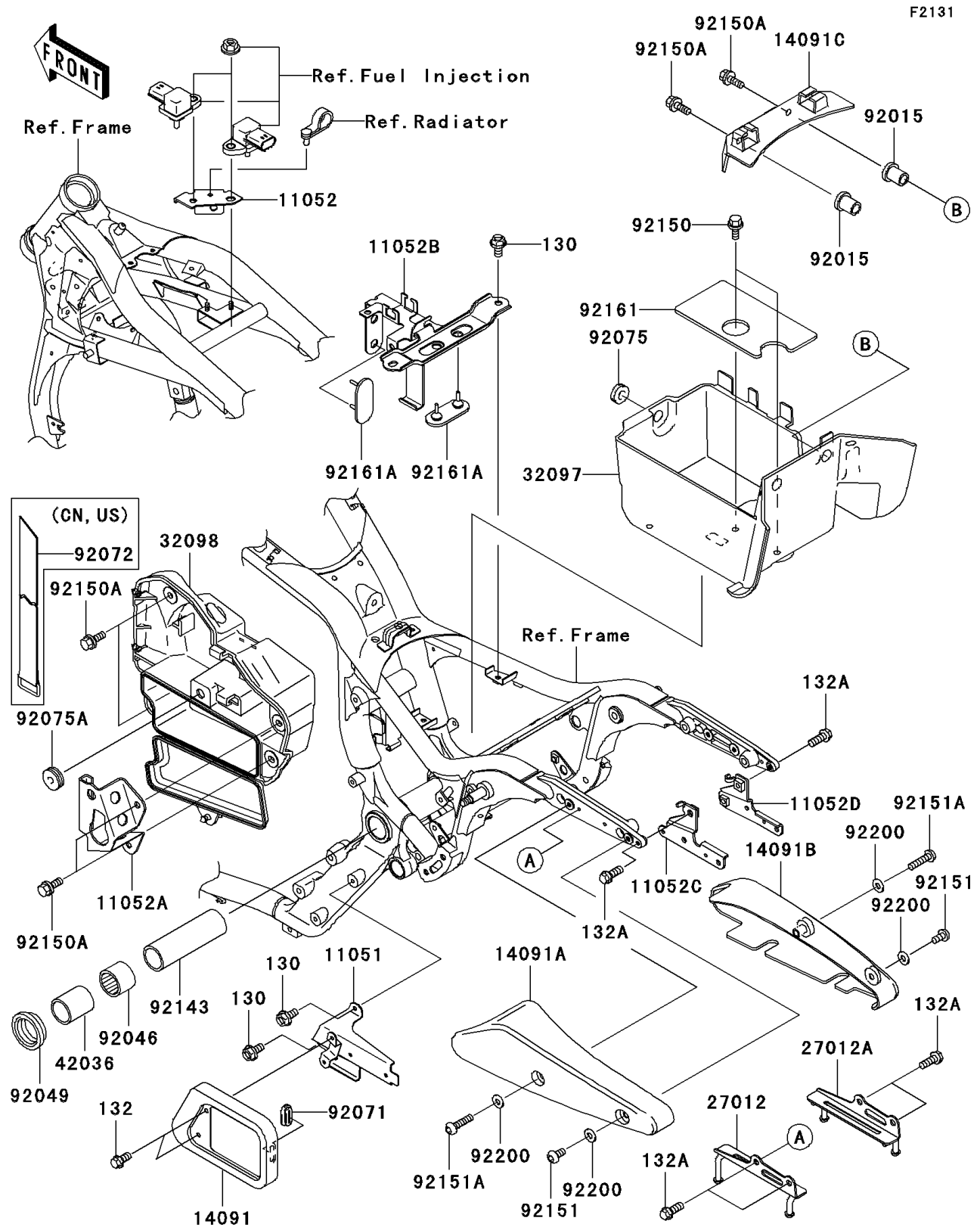

2004 Vulcan 1600 Mean Streak PARTS LIST

Frame Fittings

ITEM NAME	PART NUMBER	QUANTITY
BOLT-FLANGED (Ref # 130)	130J0612	4
BOLT-FLANGED-SMALL (Ref # 132)	132J0612	2
BOLT-FLANGED-SMALL (Ref # 132A)	132J0616	6
BRACKET,REGULATOR (Ref # 11051)	11051-1163	1
BRACKET (Ref # 11052)	11052-1071	1
BRACKET,SIDE COVER LOCK (Ref # 11052A)	11052-1234	1
BRACKET,BATTERY BAND (Ref # 11052B)	11052-1281	1
BRACKET,HELMET LOCK,LH (Ref # 11052C)	11052-1282	1
BRACKET,HELMET LOCK,RH (Ref # 11052D)	11052-1283	1
COVER,REGULATOR (Ref # 14091)	14091-1079	1
COVER,RR FENDER,LH (Ref # 14091A)	14091-1361	1
COVER,RR FENDER,RH (Ref # 14091B)	14091-1363	1
COVER,BATTERY CASE (Ref # 14091C)	14091-1373	1
HOOK,BUNGEE CORD,LH (Ref # 27012)	27012-1609	1
HOOK,BUNGEE CORD,RH (Ref # 27012A)	27012-1610	1
CASE-BATTERY (Ref # 32097)	32097-1192	1
CASE-TOOL (Ref # 32098)	32098-1137	1
SLEEVE,L=45 (Ref # 42036)	42036-1330	2
NUT (Ref # 92015)	92015-1700	2
BEARING-NEEDLE,BM2824 (Ref # 92046)	92046-1202	2
SEAL-OIL (Ref # 92049)	92049-1181	2
GROMMET (Ref # 92071)	92071-0013	1
DAMPER (Ref # 92075)	92075-1067	1
DAMPER (Ref # 92075A)	92075-1629	1
COLLAR,20.2X27X90 (Ref # 92143)	92143-1878	1
BOLT,6X14 (Ref # 92150)	92150-1133	2
BOLT,6X16 (Ref # 92150A)	92150-1198	6
BOLT,SOCKET,6X12 (Ref # 92151)	92151-1940	2
BOLT,SOCKET,6X25 (Ref # 92151A)	92151-1945	2

2004 Vulcan 1600 Mean Streak PARTS LIST

Frame Fittings

ITEM NAME	PART NUMBER	QUANTITY
DAMPER,BATTERY (Ref # 92161)	92161-1097	1
DAMPER,BATTERY BAND (Ref # 92161A)	92161-1214	2
WASHER,6.5X14.5X1.5 (Ref # 92200)	92200-3775	4
BAND,L=470 (Ref # 92072)	92072-1331	1