

1988 Voyager XII PARTS DIAGRAM

Accessory(Side Bag)

F2910B

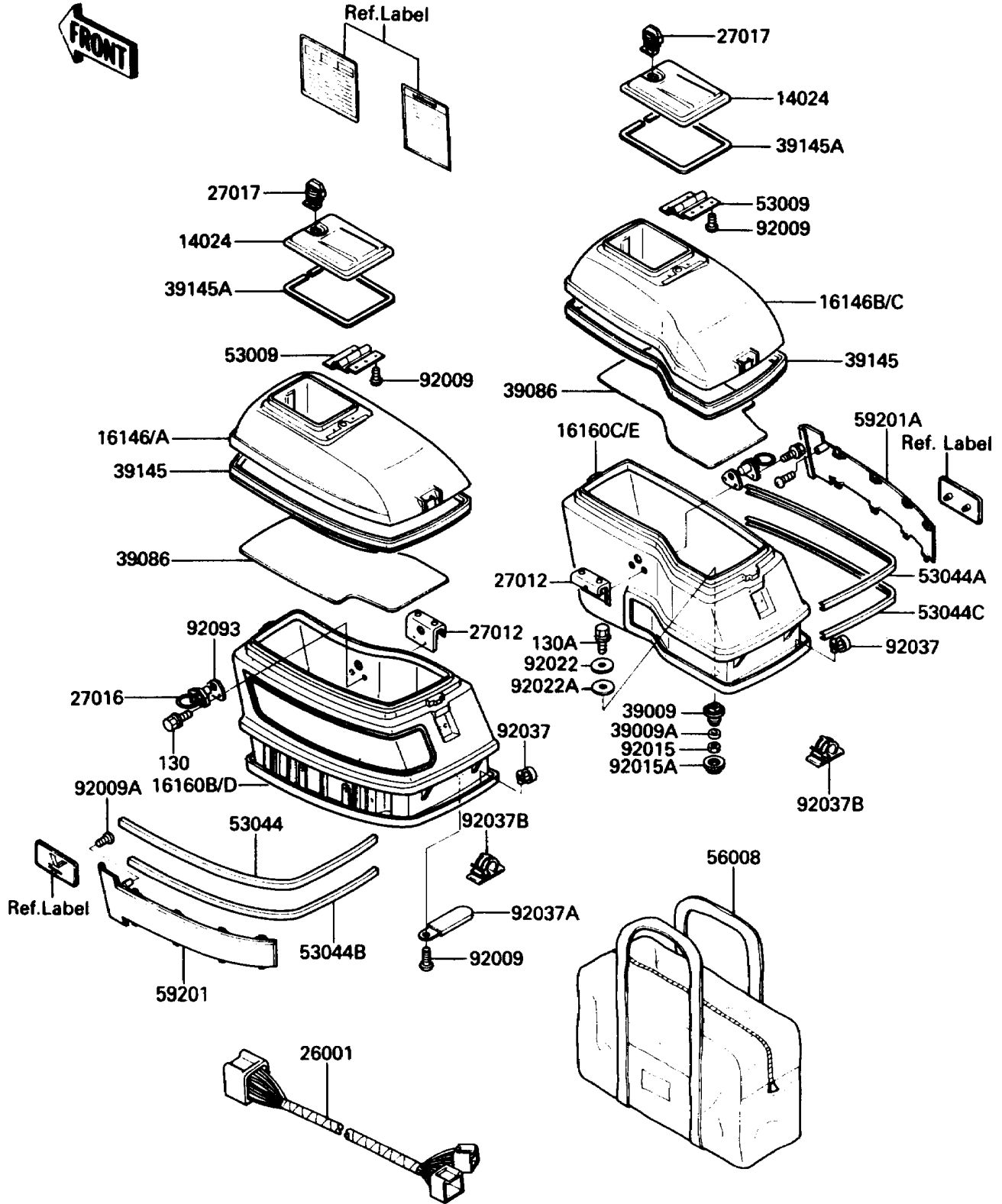

1988 Voyager XII PARTS LIST

Accessory(Side Bag)

ITEM NAME	PART NUMBER	QUANTITY
BOLT-FLANGED,6X16 (Ref # 130)	130C0616	4
BOLT-FLANGED (Ref # 130A)	130C0630	4
COVER,SIDE BAG (Ref # 14024)	14024-1178	2
COVER-ASSY,SIDE BAG,LH,BEIGE (Ref # 16146A)	16146-1063-X8	1
COVER-ASSY,SIDE BAG,RH,BEIGE (Ref # 16146C)	16146-1064-X8	1
BODY,SIDE BAG,LH,BEIGE/BEIGE (Ref # 16160B)	16160-5016-Y1	1
BODY,SIDE BAG,RH,BEIGE/BEIGE (Ref # 16160C)	16160-5017-Y1	1
HARNESS,SIDE BAG (Ref # 26001)	26001-1757	2
HOOK,SIDE BAG (Ref # 27012)	27012-1339	2
LOCK-ASSY,BAG (Ref # 27016)	27016-1054	2
LOCK,BAG (Ref # 27017)	27017-1126	2
BLOCK-MOUNT,BAG (Ref # 39009)	39009-1051	4
BLOCK-MOUNT,BAG (Ref # 39009A)	39009-1052	4
PAD-STORAGE,BAG (Ref # 39086)	39086-1052	2
TRIM-SEAL,SIDE BAG (Ref # 39145)	39145-1068	2
TRIM-SEAL,SIDE BAG (Ref # 39145A)	39145-1071	2
HINGE,SIDE BAG (Ref # 53009)	53009-1062	2
TRIM,SIDE BAG,UPP,LH (Ref # 53044)	53044-1143	1
TRIM,SIDE BAG,UPP,RH (Ref # 53044A)	53044-1144	1
TRIM,SIDE BAG,LWR,LH (Ref # 53044B)	53044-1145	1
TRIM,SIDE BAG,LWR,RH (Ref # 53044C)	53044-1146	1
BAG (Ref # 56008)	56008-1055	2
BUMPER,LH (Ref # 59201)	59201-1051	1
BUMPER,RH (Ref # 59201A)	59201-1052	1
SCREW,TAPPING,4X10 (Ref # 92009)	92009-1040	14
SCREW,TAPPING,4X14 (Ref # 92009A)	92009-1429	2
NUT,LOCK,6MM,BLACK (Ref # 92015)	92015-1191	4
NUT,BLOCK MOUNT,24MM (Ref # 92015A)	92015-1628	4
WASHER,7X28X1.6,BLACK (Ref # 92022)	92022-1392	4

1988 Voyager XII PARTS LIST

Accessory(Side Bag)

ITEM NAME	PART NUMBER	QUANTITY
WASHER,5X28X1 (Ref # 92022A)	92022-1813	4
CLAMP (Ref # 92037)	92037-1290	2
CLAMP,HARNESS (Ref # 92037A)	92037-1726	4
CLAMP,HARNESS (Ref # 92037B)	92037-1793	2
SEAL,LOCK (Ref # 92093)	92093-1209	2