

2000 Voyager XII PARTS DIAGRAM

Battery Case

F2132

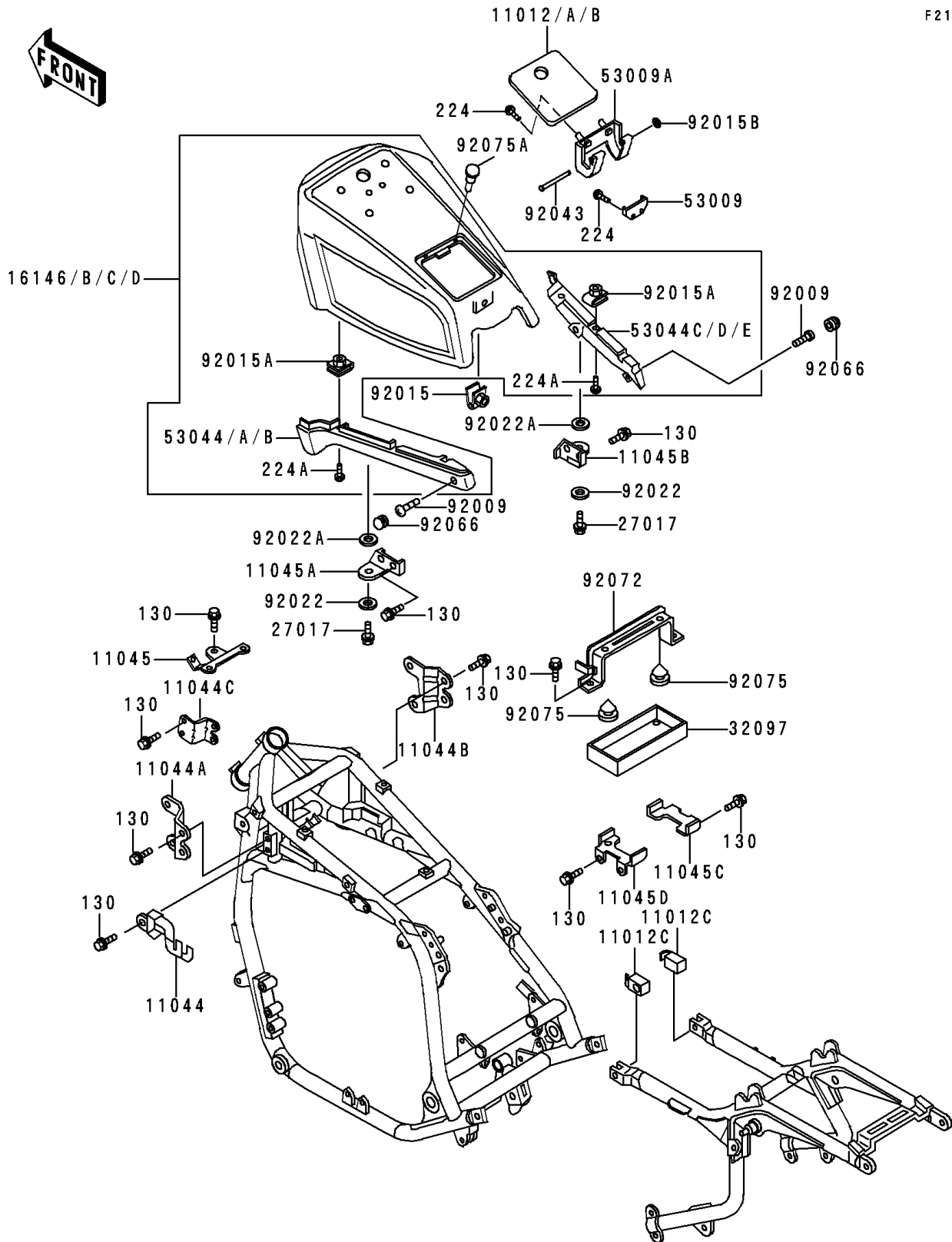

2000 Voyager XII PARTS LIST

Battery Case

ITEM NAME	PART NUMBER	QUANTITY
BOLT-FLANGED,6X10 (Ref # 130)	130B0610	17
CAP,DUMMY TANK,P.C.GRAY (Ref # 11012A)	11012-1492-VK	1
CAP (Ref # 11012C)	11012-1542	2
BRACKET,RELAY (Ref # 11044)	11044-1683	1
BRACKET,IGNITION COIL,LH (Ref # 11044A)	11044-1684	1
BRACKET,IGNITION COIL,RH (Ref # 11044B)	11044-1685	1
BRACKET,THERMOSTAT (Ref # 11044C)	11044-1686	1
BRACKET,FUSE (Ref # 11045)	11045-1056	1
BRACKET,DUMMY TANK,LH (Ref # 11045A)	11045-1077	1
BRACKET,DUMMY TANK,RH (Ref # 11045B)	11045-1078	1
BRACKET,BATTERY,RH (Ref # 11045C)	11045-1297	1
BRACKET,BATTERY,LH (Ref # 11045D)	11045-1729	1
COVER-ASSY,DUMMY TANK,SIL/GRA (Ref # 16146D)	16146-5063-V3	1
LOCK,DUMMY TANK (Ref # 27017)	27017-1124	2
CASE-BATTERY (Ref # 32097)	32097-1126	1
HINGE,DUMMY TANK (Ref # 53009)	53009-1060	1
HINGE,DUMMY TANK CAP (Ref # 53009A)	53009-1066	1
TRIM,DUMMY TANK,LH,P.C.GRAY (Ref # 53044A)	53044-1138-VK	1
TRIM,DUMMY TANK,RH,P.C.GRAY (Ref # 53044D)	53044-1139-VK	1
SCREW (Ref # 92009)	92009-1258	2
NUT,5MM (Ref # 92015)	92015-1569	2
NUT,5MM (Ref # 92015A)	92015-1573	6
NUT,PUSH,2.6MM (Ref # 92015B)	92015-1576	1
WASHER,WAVE,8MM (Ref # 92022)	92022-1776	2
WASHER,6.5MM (Ref # 92022A)	92022-1808	2
PIN,2.6X88 (Ref # 92043)	92043-1306	1
PLUG (Ref # 92066)	92066-1243	2
BAND,BATTERY (Ref # 92072)	92072-1194	1
DAMPER,RUBBER (Ref # 92075)	92075-078	2

2000 Voyager XII PARTS LIST

Battery Case

ITEM NAME	PART NUMBER	QUANTITY
DAMPER (Ref # 92075A)	92075-1808	2
SCREW-PAN-WP-CROS (Ref # 224)	224B0512	4
SCREW-PAN-WP-CROS (Ref # 224A)	224B0516	6