

1988 Voyager PARTS DIAGRAM

Secondary Shaft

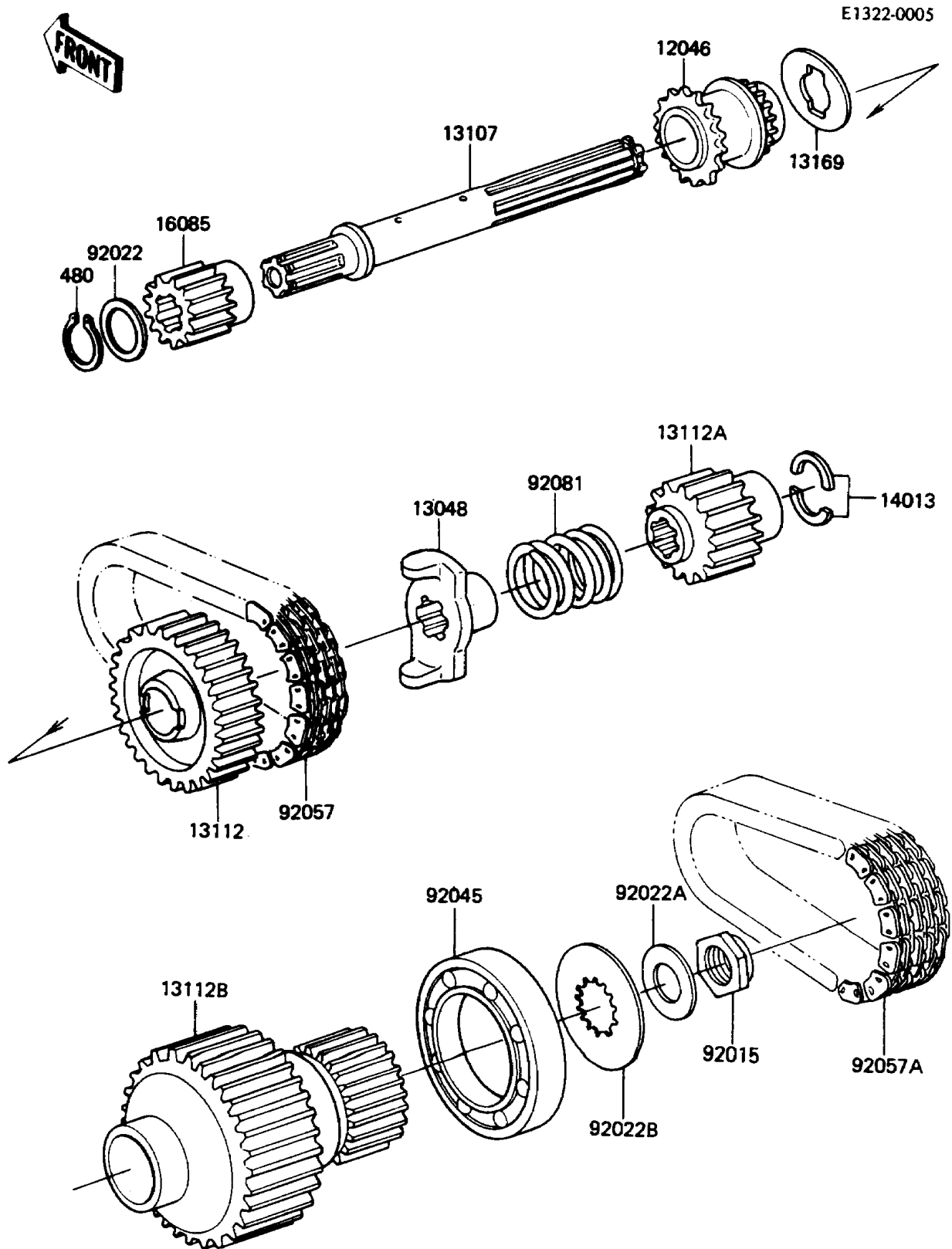

1988 Voyager PARTS LIST

Secondary Shaft

ITEM NAME	PART NUMBER	QUANTITY
SPROCKET,TIMING,28T&24T (Ref # 12046)	12046-1011	1
CAM-DAMPER,PRIMARY (Ref # 13048)	13048-1016	1
SHAFT,SECONDARY (Ref # 13107)	13107-1007	1
SPROCKET-PRIMARY,32T (Ref # 13112)	13112-1008	1
SPROCKET-PRIMARY,21T (Ref # 13112A)	13112-1010	1
SPROCKET-PRIMARY,25T (Ref # 13112B)	13112-1051	1
PLATE,SECONDARY SHAFT (Ref # 13169)	13169-1327	1
RING-POSITION (Ref # 14013)	14013-1001	2
GEAR,OIL PUMP,INPUT,19T (Ref # 16085)	16085-1004	1
NUT,20MM (Ref # 92015)	92015-1555	1
WASHER,25.3X33X1 (Ref # 92022)	92022-1109	1
WASHER,20.3X36X2.3 (Ref # 92022A)	92022-1116	1
WASHER,CLUTCH (Ref # 92022B)	92022-1404	1
BEARING-BALL,#6009 (Ref # 92045)	92045-1015	1
CHAIN,PRIMARY,50L (Ref # 92057)	92057-1075	1
CHAIN,SECONDARY (Ref # 92057A)	92057-1127	1
SPRING,CAM FOLLOWER (Ref # 92081)	92081-1085	1
CIRCLIP-TYPE-C,25MM (Ref # 480)	480J2500	1