

2009 Mule 4000 PARTS DIAGRAM

Carrier(s)

F2520

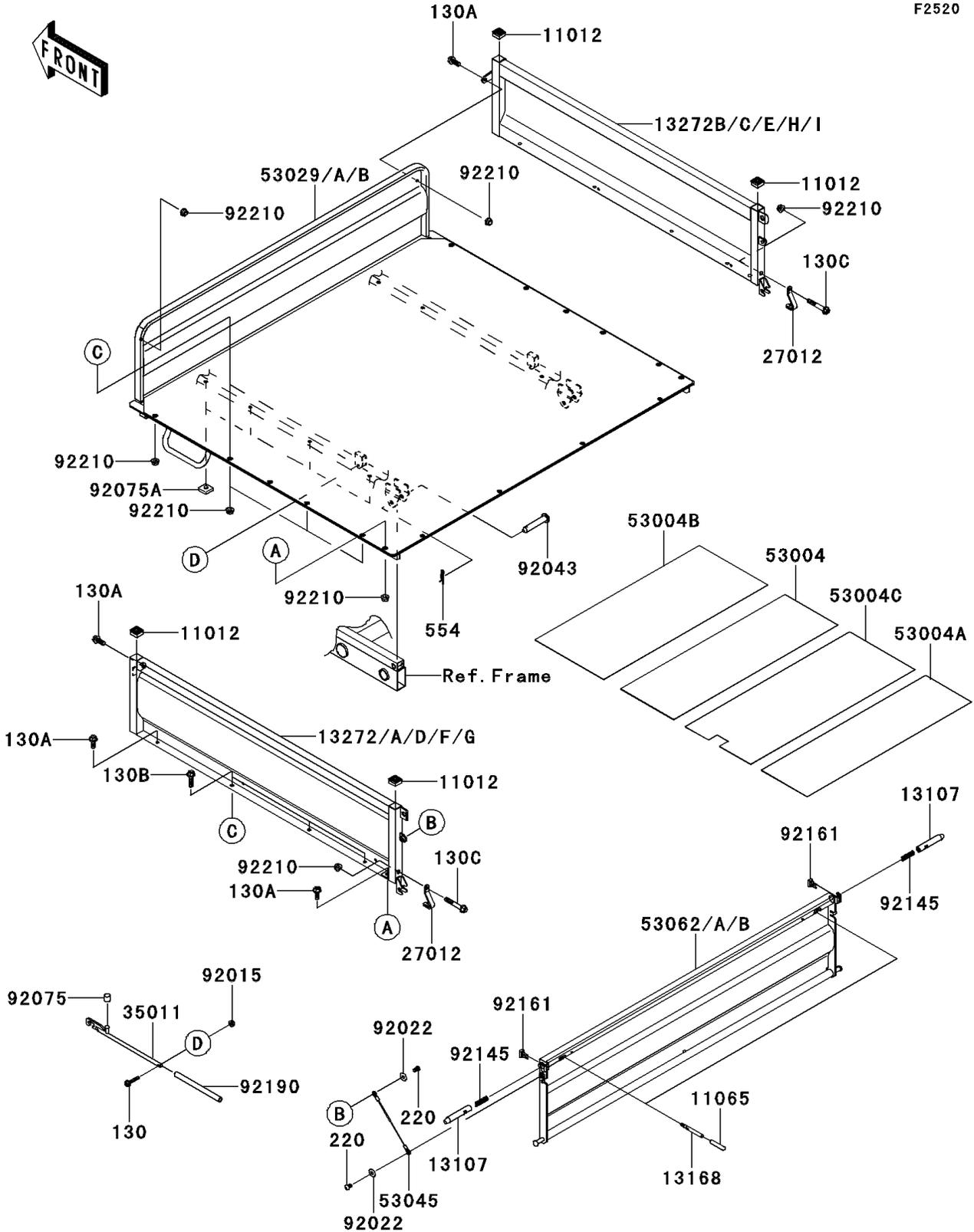

2009 Mule 4000 PARTS LIST

Carrier(s)

ITEM NAME	PART NUMBER	QUANTITY
CAP (Ref # 11012)	11012-1784	4
CAP (Ref # 11065)	11065-0126	2
SHAFT (Ref # 13107)	13107-0082	2
LEVER (Ref # 13168)	13168-0090	2
PLATE,SIDE,LH,D.R.RED (Ref # 13272)	13272-0209-16M	1
PLATE,SIDE,LH,W.GREEN (Ref # 13272A)	13272-0209-398	1
PLATE,SIDE,RH,D.R.RED (Ref # 13272B)	13272-0210-16M	1
PLATE,SIDE,RH,W.GREEN (Ref # 13272C)	13272-0210-398	1
HOOK,TAIL GATE (Ref # 27012)	27012-0022	2
STAY,CARRIER STOPPER (Ref # 35011)	35011-1648	1
MAT,CARRIER (Ref # 53004)	53004-0031	1
MAT,CARRIER (Ref # 53004A)	53004-0032	1
MAT,CARRIER (Ref # 53004B)	53004-0034	1
MAT (Ref # 53004C)	53004-1159	1
CARRIER,BASE PLATE,D.R.RED (Ref # 53029)	53029-0063-16M	1
CARRIER,BASE PLATE,W.GREEN (Ref # 53029B)	53029-0063-398	1
HOOK-ASSY,TAIL GATE (Ref # 53045)	53045-0004	2
GATE-TAIL,D.R.RED (Ref # 53062)	53062-0001-16M	1
GATE-TAIL,W.GREEN (Ref # 53062A)	53062-0001-398	1
NUT,LOCK,FLANGED,6MM (Ref # 92015)	92015-1675	1
WASHER,7X18X1.2 (Ref # 92022)	92022-1545	4
PIN,12X65 (Ref # 92043)	92043-1428	2
DAMPER (Ref # 92075)	92075-1817	1
DAMPER (Ref # 92075A)	92075-1882	8
SPRING,TENSIONER (Ref # 92145)	92145-1215	2
DAMPER (Ref # 92161)	92161-0258	2
TUBE,13X16X200 (Ref # 92190)	92190-1401	1
NUT,FLANGED,8MM (Ref # 92210)	92210-0555	14
BOLT-FLANGED,6X30 (Ref # 130)	130BA0630	1

2009 Mule 4000 PARTS LIST

Carrier(s)

ITEM NAME	PART NUMBER	QUANTITY
BOLT-FLANGED,8X20 (Ref # 130A)	130BB0820	6
BOLT-FLANGED,8X30 (Ref # 130B)	130BB0830	6
BOLT-FLANGED,8X50 (Ref # 130C)	130BB0850	2
SCREW-PAN-CROSS,6X10 (Ref # 220)	220AB0610	4
PIN-SNAP,12MM (Ref # 554)	554DA1200	2