

# 1991 Zephyr 750 PARTS DIAGRAM

Electrical Equipment

F2760

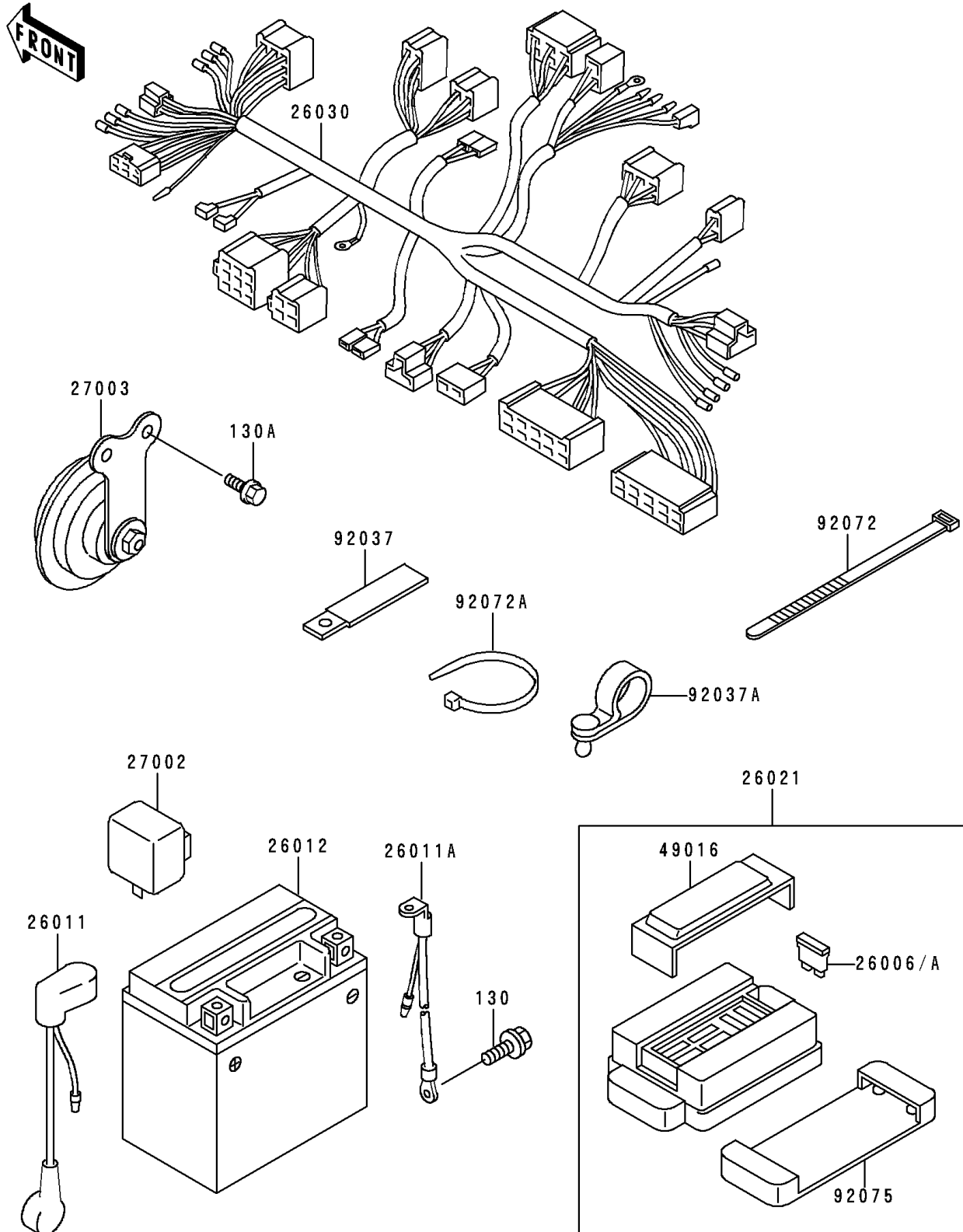

# 1991 Zephyr 750 PARTS LIST

## Electrical Equipment

ITEM NAME	PART NUMBER	QUANTITY
BOLT-FLANGED,6X10 (Ref # 130)	130B0610	1
BOLT-FLANGED,6X12 (Ref # 130A)	130C0612	2
FUSE,30A-G (Ref # 26006)	26006-1006	2
FUSE,10A-R (Ref # 26006A)	26006-1007	4
WIRE-LEAD,BATTERY(+) (Ref # 26011)	26011-1188	1
WIRE-LEAD,BATTERY(-) (Ref # 26011A)	26011-1402	1
BATTERY,YTX12-BS,12V 10AH (Ref # 26012)	26012-1253	1
JUNCTION BOX (Ref # 26021)	26021-1079	1
HARNESS,MAIN (Ref # 26030)	26030-1066	1
RELAY-ASSY,TURN SIGNAL (Ref # 27002)	27002-1053	1
HORN (Ref # 27003)	27003-1348	1
COVER-SEAL,FUSE (Ref # 49016)	49016-1106	1
CLAMP,WIRING HARNESS (Ref # 92037)	92037-1069	3
CLAMP (Ref # 92037A)	92037-1290	2
BAND,L=185 (Ref # 92072)	92072-1195	8
BAND,L=365 (Ref # 92072A)	92072-1197	1
DAMPER,JUNCTION BOX (Ref # 92075)	92075-1688	1