

1988 NINJA® ZX-10 PARTS DIAGRAM

Battery Case

F2132-0188

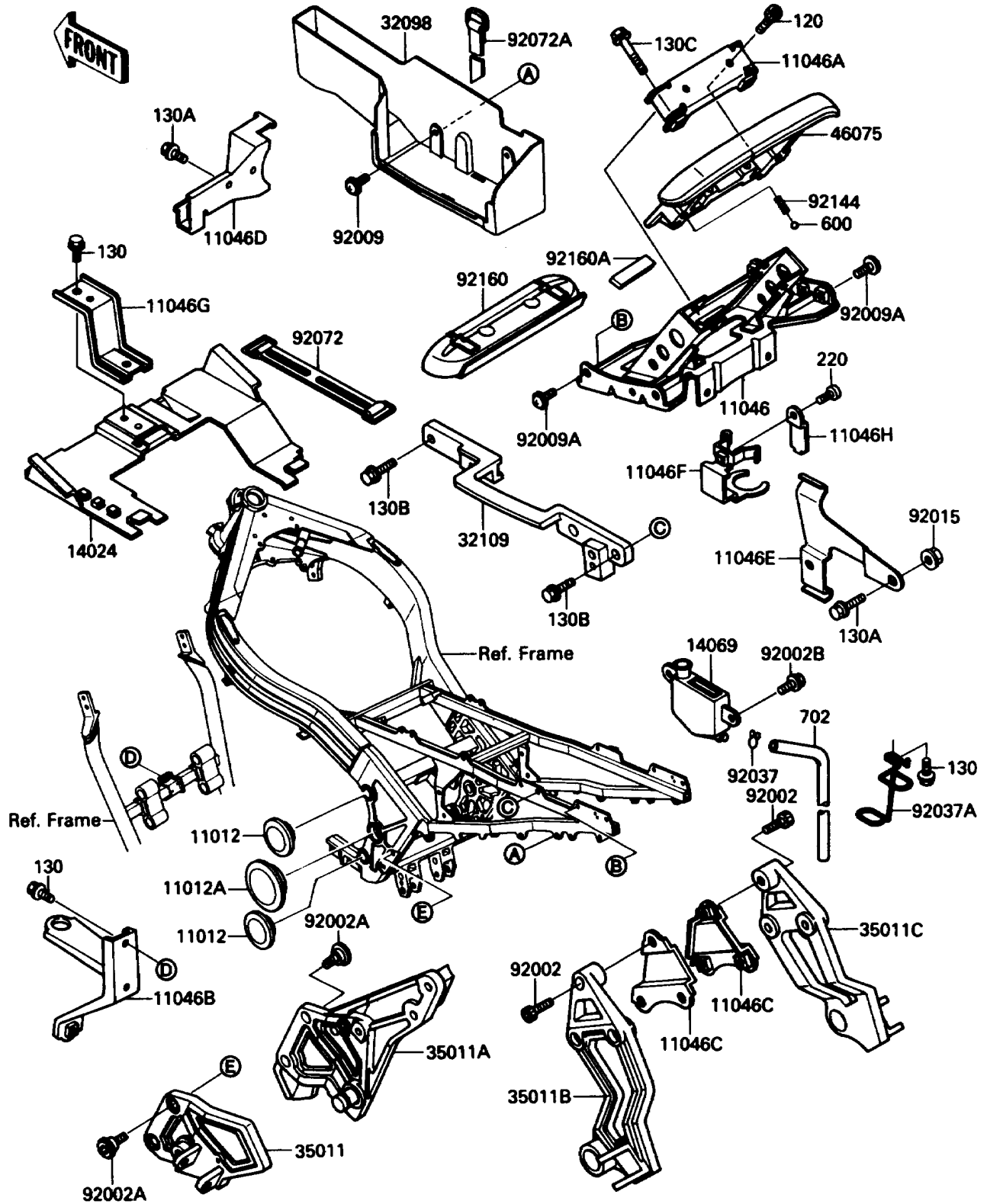

1988 NINJA® ZX-10 PARTS LIST

Battery Case

ITEM NAME	PART NUMBER	QUANTITY
BOLT-SOCKET (Ref # 120)	120S0814	2
BOLT-FLANGED (Ref # 130)	130J0610	5
CAP (Ref # 11012)	11012-1460	4
CAP (Ref # 11012A)	11012-1657	2
BRACKET,TAIL GRIP (Ref # 11046)	11046-1239	1
BRACKET,TAIL GRIP (Ref # 11046A)	11046-1240	1
BRACKET,OIL COOLER (Ref # 11046B)	11046-1260	1
BRACKET,MUFFLER STAY (Ref # 11046C)	11046-1261	2
BRACKET,FUEL PUMP (Ref # 11046D)	11046-1262	1
BRACKET,BATTERY CASE (Ref # 11046G)	11046-1369	1
COVER,RR (Ref # 14024)	14024-1693	1
BREATHER (Ref # 14069)	14069-1054	1
CASE-TOOL (Ref # 32098)	32098-1081	1
GRIP-FRAME,LH (Ref # 32109)	32109-1171	1
STAY,STEP HOLDER,LH,SILVER (Ref # 35011)	35011-1416-CE	1
STAY,STEP HOLDER,RH,SILVER (Ref # 35011A)	35011-1417-CE	1
STAY,MUFFLER,LH,SILVER NO.25 (Ref # 35011B)	35011-1425-CE	1
STAY,MUFFLER,RH,SILVER NO.25 (Ref # 35011C)	35011-1426-CE	1
GRIP,TAIL,BLACK (Ref # 46075)	46075-1076-10	1
BOLT,SOCKET,8X22 (Ref # 92002)	92002-1334	6
BOLT,SOCKET,8X20 (Ref # 92002A)	92002-1493	4
BOLT,6X12 (Ref # 92002B)	92002-1884	2
SCREW,6X18,BLACK (Ref # 92009)	92009-1181	2
SCREW,8X16 (Ref # 92009A)	92009-1556	4
CLAMP,TUBE (Ref # 92037)	92037-147	1
CLAMP,HOSE (Ref # 92037A)	92037-1875	1
BAND,L=146.9 (Ref # 92072)	92072-054	1
BAND,L=300 (Ref # 92072A)	92072-1235	1
SPRING (Ref # 92144)	92144-3708	2

1988 NINJA® ZX-10 PARTS LIST

Battery Case

ITEM NAME	PART NUMBER	QUANTITY
DAMPER,TAIL GRIP (Ref # 92160)	92160-1054	1
DAMPER (Ref # 92160A)	92160-1099	1
BOLT-FLANGED,8X20 (Ref # 130B)	130J0820	2
BOLT-FLANGED,8X40 (Ref # 130C)	130J0840	2
BALL-STEEL,1/4" (Ref # 600)	600A0800	2
TUBE-RUBBER,7X10X380 (Ref # 702)	702A07380	1
BOLT-FLANGED,6X16,BLACK (Ref # 130A)	130J0616	2
BOLT-FLANGED,6X16,BLACK (Ref # 130A)	130J0616	3
BRACKET,CANISTER (Ref # 11046E)	11046-1277	1
BRACKET,SEPARATOR (Ref # 11046F)	11046-1278	1
BRACKET,SEPARATOR (Ref # 11046H)	11046-1372	1
NUT,FLANGED,6MM (Ref # 92015)	92015-1367	1
SCREW-PAN-CROS (Ref # 220)	220C0510	1