

Mule 2510 4X4 PARTS DIAGRAM

Crankcase

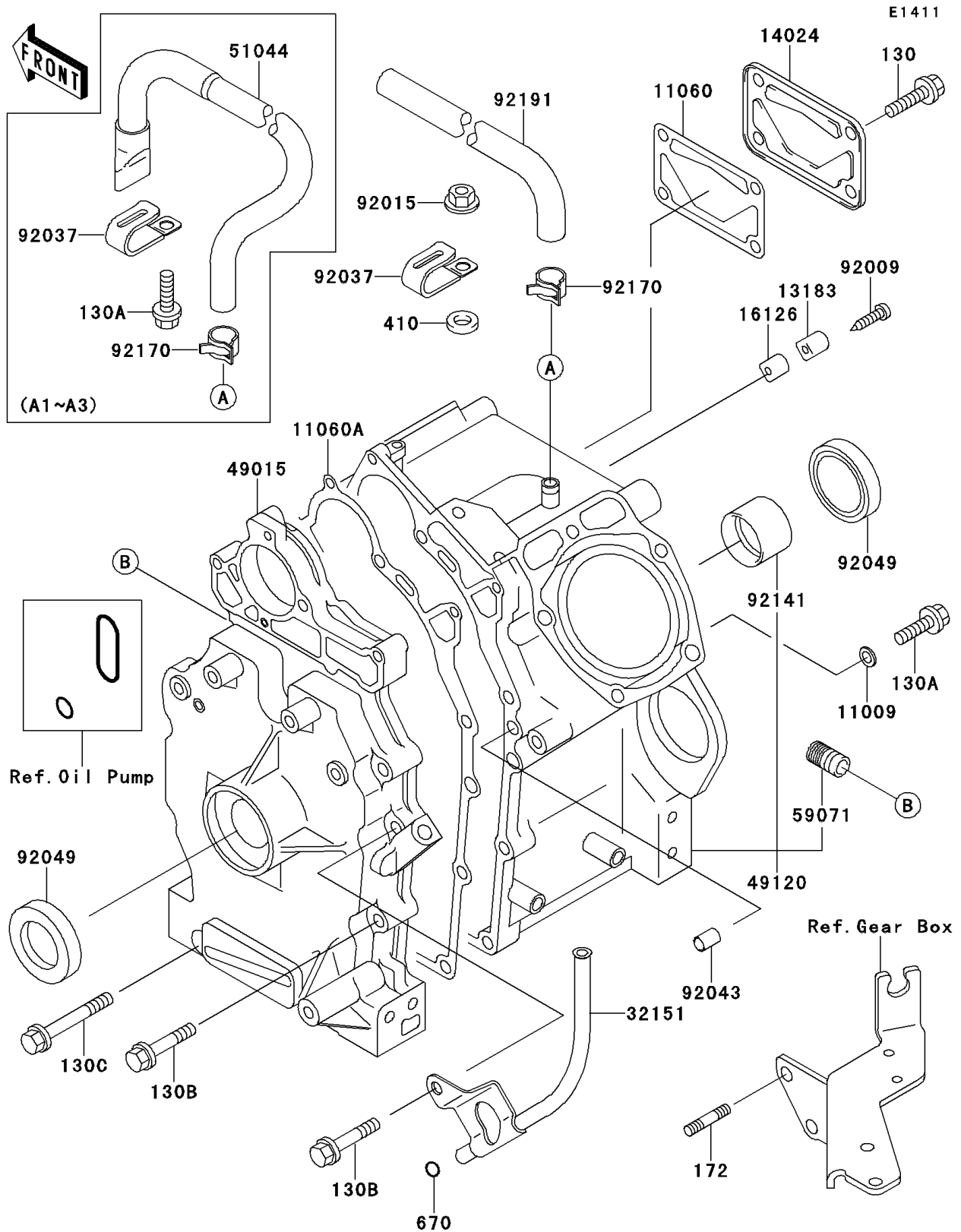

Mule 2510 4X4 PARTS LIST

Crankcase

ITEM NAME	PART NUMBER	QUANTITY
BOLT-FLANGED,8X16 (Ref # 130)	130B0816	4
BOLT-FLANGED,8X12,BLACK (Ref # 130A)	130C0812	3
BOLT-FLANGED,8X45 (Ref # 130B)	130G0845	6
BOLT-FLANGED,8X60 (Ref # 130C)	130G0860	2
BOLT-STUD,8X25 (Ref # 172)	172G0825	2
O RING,10MM (Ref # 670)	670B2010	1
GASKET (Ref # 11009)	11009-3028	2
GASKET (Ref # 11060)	11060-2089	1
GASKET,CRANKCASE COVER (Ref # 11060A)	11060-2284	1
PLATE (Ref # 13183)	13183-2120	1
COVER (Ref # 14024)	14024-2292	1
VALVE (Ref # 16126)	16126-2146	1
PIPE,OIL GAUGE,F.BLACK (Ref # 32151)	32151-2032-9H	1
COVER-CRANKCASE (Ref # 49015)	49015-6193	1
CRANKCASE-COMP (Ref # 49120)	49120-6078	1
TUBE-ASSY (Ref # 51044)	51044-2080	1
JOINT (Ref # 59071)	59071-2079	1
SCREW (Ref # 92009)	92009-2308	1
CLAMP (Ref # 92037)	92037-2101	1
PIN,DOWEL,10X14 (Ref # 92043)	92043-1037	2
SEAL-OIL (Ref # 92049)	92049-2110	2
BEARING-PLANE (Ref # 92141)	92141-2110	1
CLAMP (Ref # 92170)	92170-3714	1