

Mule 3010 4x4 Advantage Classic PARTS DIAGRAM

Frame(H1)

F2120

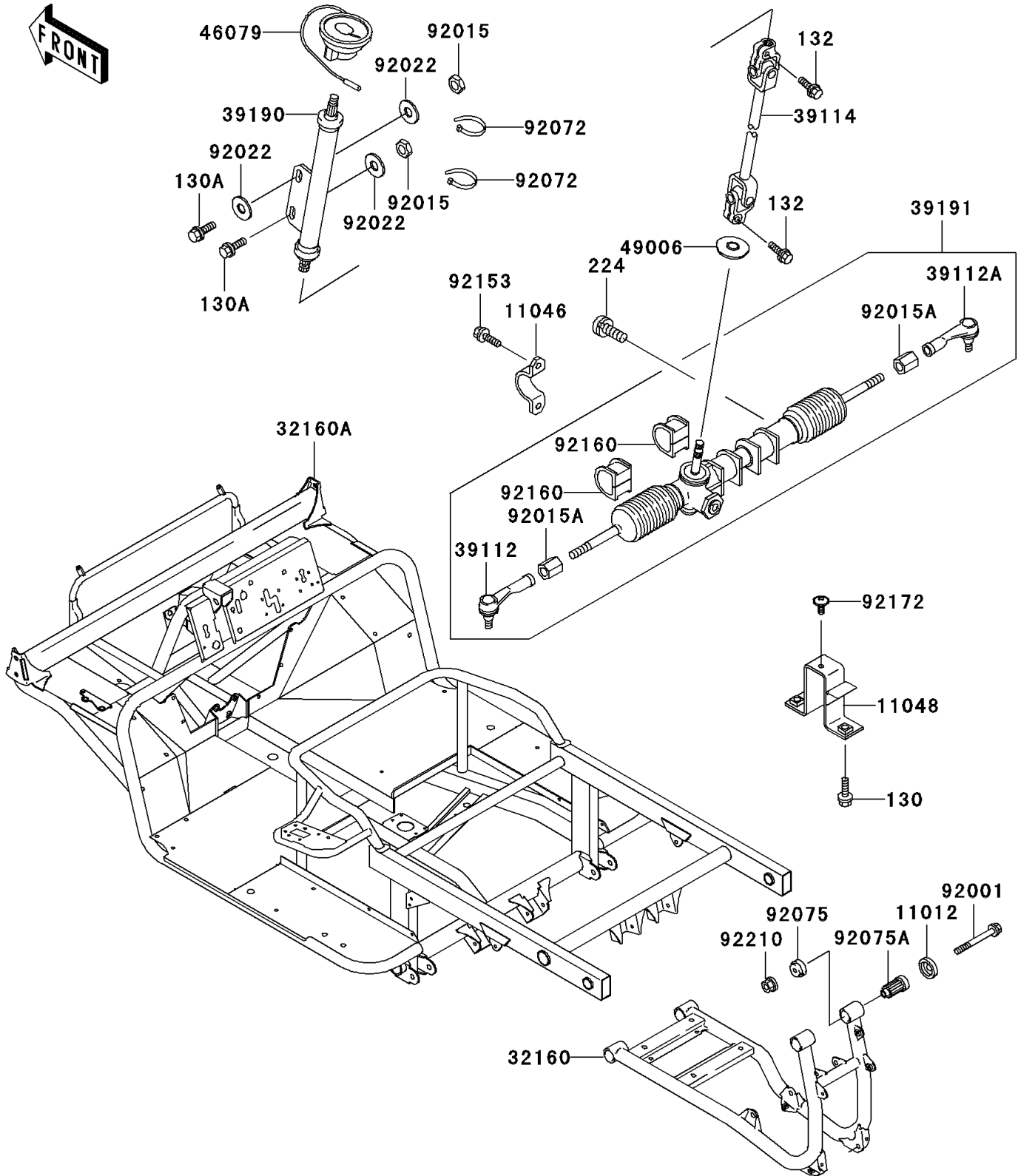

Mule 3010 4x4 Advantage Classic PARTS LIST

Frame(H1)

ITEM NAME	PART NUMBER	QUANTITY
BOLT-FLANGED,8X20 (Ref # 130)	130J0820	2
BOLT-FLANGED,10X30 (Ref # 130A)	130J1030	2
BOLT-FLANGED-SMALL (Ref # 132)	132J0825	2
SCREW-PAN-WP-CROS (Ref # 224)	224B0508	1
CAP,ENGINE BRACKET (Ref # 11012)	11012-1228	4
BRACKET,STEERING GEAR (Ref # 11046)	11046-1858	2
BRACKET,REAR FRAME (Ref # 11048)	11048-1245	1
FRAME-COMP,RR (Ref # 32160)	32160-7506	1
UNAVAILABLE (Ref # 32160A)	N/A	1
RODEND-TIE,STEERING GEAR,LH (Ref # 39112)	39112-1068	1
RODEND-TIE,STEERING GEAR,RH (Ref # 39112A)	39112-1069	1
SHAFT-COMP-STRG (Ref # 39114)	39114-1070	1
SHAFT-ASSY-STEERING (Ref # 39190)	39190-1006	1
GEAR-ASSY-STEERING (Ref # 39191)	39191-1007	1
CONTACT,HORN SWITCH (Ref # 46079)	46079-1063	1
BOOT,STEERING SHAFT,LWR (Ref # 49006)	49006-1255	1
BOLT,FLANGED,10X85 (Ref # 92001)	92001-1619	4
NUT,LOCK,10MM,BLACK (Ref # 92015)	92015-1189	2
NUT (Ref # 92015A)	92015-1864	2
WASHER,10.5X26X2.3,BLACK (Ref # 92022)	92022-1396	3
BAND,L=188 (Ref # 92072)	92072-1239	2
DAMPER,ENGINE MOUNT,SIDE (Ref # 92075)	92075-1274	4
DAMPER,ENGINE MOUNT,MAIN (Ref # 92075A)	92075-1377	4
BOLT,SOCKET,10X23 (Ref # 92153)	92153-1269	4
DAMPER,STEERING GEAR (Ref # 92160)	92160-1084	2
SCREW,6X14 (Ref # 92172)	92172-0004	1
NUT,LOCK,FLANGED,10MM (Ref # 92210)	92210-1081	4